



This is a digital copy of a book that was preserved for generations on library shelves before it was carefully scanned by Google as part of a project to make the world's books discoverable online.

It has survived long enough for the copyright to expire and the book to enter the public domain. A public domain book is one that was never subject to copyright or whose legal copyright term has expired. Whether a book is in the public domain may vary country to country. Public domain books are our gateways to the past, representing a wealth of history, culture and knowledge that's often difficult to discover.

Marks, notations and other marginalia present in the original volume will appear in this file - a reminder of this book's long journey from the publisher to a library and finally to you.

Usage guidelines

Google is proud to partner with libraries to digitize public domain materials and make them widely accessible. Public domain books belong to the public and we are merely their custodians. Nevertheless, this work is expensive, so in order to keep providing this resource, we have taken steps to prevent abuse by commercial parties, including placing technical restrictions on automated querying.

We also ask that you:

- + *Make non-commercial use of the files* We designed Google Book Search for use by individuals, and we request that you use these files for personal, non-commercial purposes.
- + *Refrain from automated querying* Do not send automated queries of any sort to Google's system: If you are conducting research on machine translation, optical character recognition or other areas where access to a large amount of text is helpful, please contact us. We encourage the use of public domain materials for these purposes and may be able to help.
- + *Maintain attribution* The Google "watermark" you see on each file is essential for informing people about this project and helping them find additional materials through Google Book Search. Please do not remove it.
- + *Keep it legal* Whatever your use, remember that you are responsible for ensuring that what you are doing is legal. Do not assume that just because we believe a book is in the public domain for users in the United States, that the work is also in the public domain for users in other countries. Whether a book is still in copyright varies from country to country, and we can't offer guidance on whether any specific use of any specific book is allowed. Please do not assume that a book's appearance in Google Book Search means it can be used in any manner anywhere in the world. Copyright infringement liability can be quite severe.

About Google Book Search

Google's mission is to organize the world's information and to make it universally accessible and useful. Google Book Search helps readers discover the world's books while helping authors and publishers reach new audiences. You can search through the full text of this book on the web at <http://books.google.com/>



QB 25 942

INTERNAL COMBUSTION ENGINE MANUAL

—STERLING

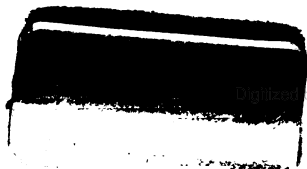
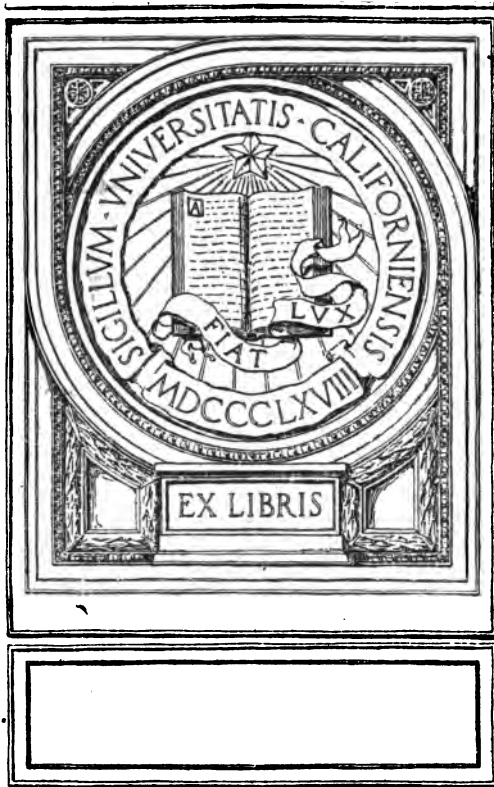

Internal Combustion Engine Manual

INTERNAL COMBUSTION ENGINE MANUAL

BY
F. W. STERLING
Lieutenant, U. S. Navy

UNIVERSITY OF
CALIFORNIA

ANNAPOLIS, MARYLAND
SCHOOL OF MARINE ENGINEERING
U. S. NAVAL ACADEMY
1911

TJ 755
78

COPYRIGHT, 1911
BY
F. W. STERLING

TO THE
LIBRARY OF
CONGRESS

The Lord Baltimore Press
BALTIMORE, MD., U. S. A.

88

FOREWORD.

In an effort to present briefly and clearly the Internal Combustion Engine problem to the uninitiated, the author has compiled the data in this volume. It has been the endeavor to eliminate all obsolete practice, to put forth the best modern practice, and to illustrate all points by up-to-date commercial examples.

After close study of the conditions existing in the Internal Combustion Engine course at the U. S. Naval Academy, and after voluminous reading to discover the best general method of presenting the subject, the following was thought the best sequence to follow:

(a) The subject of fuels is first treated fully, this being the fundamental element that governs design and operation. These fuels follow in a natural sequence which order is preserved when carburetion is taken up in Chapter V.

(b) The engine proper naturally divides itself into four systems: (1) fuel system, (2) ignition system, (3) cooling system, (4) lubrication system. These are treated in detail in the above order and in Chapter X the four systems assembled are illustrated by modern commercial engines.

(c) Producer plants being closely allied to gas engines are given a short chapter at the end of the book.

This volume being primarily intended as a text-book for midshipmen is necessarily limited in its scope by the time allowed for this course in the Naval Academy curriculum. This necessitates brevity and is responsible for many arbitrary statements contained herein. The endeavor has been to limit these to the closest approximation to the best practices where fuller explanation would extend the book to impossible limits.

The author wishes to thank the various manufacturers for the illustrations used in Chapter X, and the Hill Publishing Company for permission to reproduce some of the figures in Chapter XI.

CONTENTS

CHAPTER	PAGE
1. FUELS	1
2. GENERAL	15
3. CONSTRUCTION	23
4. TYPES, CYCLES, ETC.....	34
5. CARBURETION, THE MIXTURE, ITS PREPARATION, CARBURETERS AND VAPORIZERS	42
6. IGNITION	52
7. COOLING AND LUBRICATION.....	64
8. GOVERNING AND INDICATOR CARDS.....	69
9. EFFICIENCY, MANAGEMENT, OPERATION, DEFECTS AND REMEDIES..	82
10. ENGINES	94
11. GAS PRODUCERS	126

INTERNAL COMBUSTION ENGINE MANUAL

CHAPTER I

FUELS

The considerations governing the selection of a fuel in general are its accessibility, price, amount available, rate of combustion, and thermal value; it does not naturally follow that these are the only limitations which shall regulate the choice of a fuel for use in an internal combustion engine. This being a specific form of engine requires special consideration.

Fuel for use in an internal combustion engine must readily combine with air to form a combustible mixture of gas or vapor, must leave little or no solid residue after combustion, and must have certain thermo-chemical characteristics such as a proper rate of flame propagation, etc. It need not necessarily be of a very high calorific value, as will be shown later, but obviously this is desirable. The fuel is usually a compound of carbon and hydrogen, or a mixture of such compounds, found thus in nature or manufactured.

The general classification of internal combustion engine fuels is:

1. The solid fuels.
2. The liquid fuels.
3. The gaseous fuels.

Solid fuels cannot be used in an internal combustion engine in their natural state, hence coal and other carbonaceous solids must be gasified to *CO* and *H* by partial combustion and volatilization to prepare them for such use. Although the Diesel engine was originally designed to use coal dust for fuel, and experiments have been made along this line, the idea was finally abandoned.

Solid fuels are converted into (a) *air gas*, (b) *water gas*, (c) *producer gas*.

Liquid fuels comprise (a) *distillates of petroleum* or *crude oil*, and (b) *alcohol*.

The gaseous fuels consist of (a) *oil gas*, (b) *illuminating gas*, (c) *coke oven gas*, (d) *blast furnace gas*, (e) *natural gas*, and (f) *acetylene*.

Of all these fuels the most important from the marine standpoint is petroleum.

1. Solid Fuels

A. AIR GAS

Although entitled to no commercial consideration because of its rarity, air gas must be mentioned here as a possible fuel. It can be manufactured by the gasification of carbon by incomplete combustion to CO in a producer.

The complete combustion to CO_2 of 1 pound of carbon would generate 14,650 B. T. U. Partial combustion to CO of the same carbon would liberate about 4430 B. T. U. Therefore, if this CO could be led from the producer, it would be a gaseous fuel containing 10,220 B. T. U. *per pound of carbon*. Since each pound of carbon is combined with $1\frac{1}{2}$ pounds of O when the CO is formed, the gas contains 10,220 B. T. U. per $2\frac{1}{2}$ pounds, or about 4380 B. T. U. per pound of gas. Of course this is an ideal condition impossible of attainment by any commercial apparatus on the market.

B. WATER GAS

If incandescent fuel is sprayed with water vapor, the H_2O is dissociated to H_2 and O , and the latter combines with the carbon in the fuel to form CO_2 or CO . H_2 is liberated. At temperatures below $1250^\circ F.$, CO_2 is formed, whereas, if the temperature be above $1800^\circ F.$, CO alone is formed.

The reactions are:

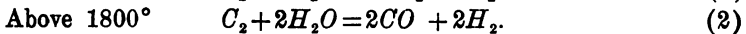
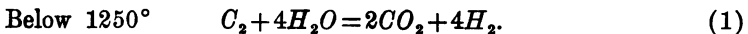

By formula (2) it is found that the gas formed by 1 *pound of carbon*, when converted into CO and H_2 by this method, will contain 20,742 B. T. U., or about 8300 B. T. U. per pound of gas.

When converted by formula (1), 1 pound of gas will contain 5278 B. T. U.

From these figures it might appear that this were an efficient gas production; on the contrary, water gas, reckoned on the basis of coal used, is not highly efficient for the following reason: starting with a fuel in the incandescent state, the continued introduction of water vapor will cool the producer and when the temperature falls below 1800° F. an excessive amount of CO_2 is formed. Unless some means is devised to counteract this cooling action the process will finally cease. Practical generation of water gas is accomplished in a producer. When the temperature becomes too low the steam is shut off and the fuel is again brought to incandescence by blowing through with air. During this "blowing up" process gas of a low grade is formed. This is rarely utilized and here we find the important loss which accounts for the low efficiency of water gas as calculated upon the basis of coal consumed.

C. PRODUCER GAS

Producer gas is formed by blowing a *mixture of water vapor and air* through a bed of incandescent fuel. Thus it is a combination of the two previous gases. Gas producers for the generation of this gas have reached a high degree of perfection and hold a large commercial field. They are used extensively in stationary gas engine plants and in a few instances have been adapted to marine use. As their importance justifies a chapter on the subject, it will be treated later. The scope of this work prohibits the computation, but it can be shown that the theoretical product of a gas producer contains about 14,000 B. T. U. per pound of carbon consumed.

In these discussions of the three classes of gas formed from solid fuels the B. T. U. per pound of carbon have been shown. This gives an idea of their thermal value based upon the amount of solid fuel used and must not be confused with their relative thermal values per cubic foot of gas. It must be borne in mind that all the figures are theoretical.

2. Liquid Fuels

A. PETROLEUM AND ITS DISTILLATES

By far the most important fuels for marine internal combustion engines are derived from petroleum. This important product is found in nearly every part of the globe. The United States and Russia produce most of the petroleum at present. In this country the fields of Pennsylvania, Ohio, Oklahoma, Texas and California are the best producers.

Contrary to the popular idea, oil is not necessarily found in the vicinity of coal fields, but near salt deposits, the formation of salt and oil being apparently simultaneous. Although, still open to dispute, it appears to be fairly well established that petroleum was formed by the decomposition of large masses of organic matter, probably of marine origin, and the subsequent spontaneous distillation of the hydrocarbons from such matter. Some few petroleum products seem to be of vegetable origin.

One of the most interesting experiments in support of this organic theory of the origin of petroleum was conducted by Engler. He distilled menhaden (fish) oil between the temperatures of 320° C. at 10 atmospheres pressure and 400° C. at 4 atmospheres pressure, resulting in 60 per cent of distillate, having a specific gravity of 0.81. The residue contained some unsaponifiable fat. Fractionation of the distillate showed the presence of members of the hydrocarbon group ranging from pentane to nonane, and finally, a lighting oil was separated which was indistinguishable from commercial kerosene.

As found in its natural state its composition varies with the field of supply, but in every case consists of *C* and *H* with a small amount of *O* and impurities, the average for 13 fields being *C* 84 per cent, *H* 13.5 per cent, *O* and impurities 2.5 per cent. The greatest variation from this in any one field is 2.5 per cent *C*. Its specific gravity (considering only those fields of commercial value) varies from 0.826 found in a Pennsylvania field to 0.956 found in the Baku region. A field in Kaduka, Russia, yields a crude oil with the low specific gravity of 0.65, and in Mexico an oil is obtained with the high specific gravity of 1.06.

Petroleum products are obtained by what is known as fractional distillation. The fractionation is conducted as follows:

The horizontal still shown in Fig. 1 may be charged with 600 barrels of petroleum. A fire is built on the grate and when the oil is sufficiently heated, shown by an even ebullition, superheated

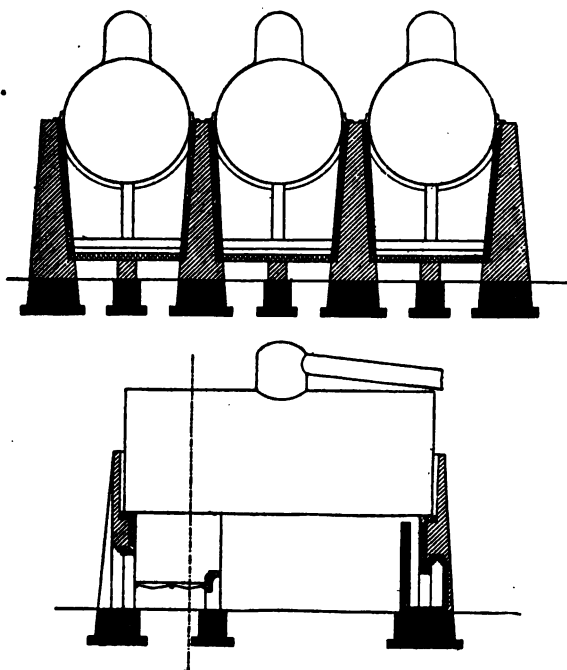

FIG. 1.—American Horizontal Cylindrical Still.

steam is introduced to the still, and distillation commences. A temperature of 130° to 200° C. is maintained in the still and all the kerosene and less volatile products are distilled off, passing to the deflegmator on the still head, Fig. 2. This acts as a separator, returning any oil which is mechanically carried over to the still, through the pipe *a*. From the deflegmator the distillate passes to the condenser. As the process progresses, the temperature is raised to 250° to 300° C. and at this temperature the lubricating fractions

are obtained. These temperatures vary with the petroleum being distilled and with the form of still used. The residue contains cylinder oil and greases. These three fractions are usually obtained at the first distillation. By the use of superheated steam the high temperature necessary for distillation is obtained at a lower pressure than would be the case in simple distillation, and the steam carries the vapors away to the condenser as fast as they are generated, the injury to the products resulting from their remaining in

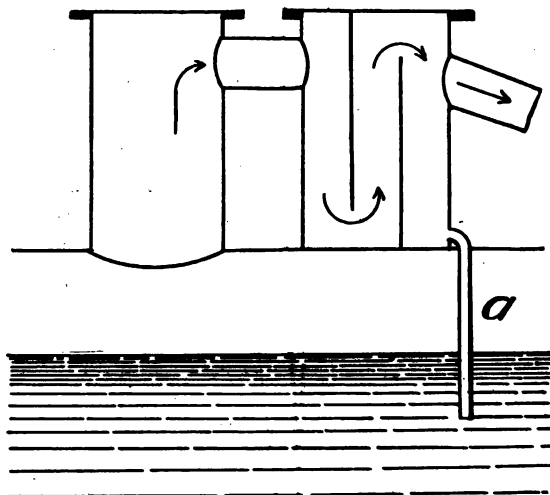

FIG. 2.—Deflegmator.

contact with the highly heated surface of the still thus being prevented.

To obtain the commercial products a second distillation of these fractions is necessary. Redistillation of the first fraction gives petroleum ether, gasoline, benzine, naphtha and kerosene. Redistillation of the residue gives cylinder oil, vaseline and residuum.

The products obtained are not in a marketable condition until chemically treated to remove impurities. The water present is settled out. In the case of lubricating and heavier oils, steam coils in the settling tanks aid this settling process by temporarily re-

ducing the viscosity of the oil. After the water is removed, the distillate is treated with sulphuric acid followed by soda lye. The rationale of this treatment is not fully understood, but the action appears to consist of the removal or decomposition of the aromatic hydrocarbons, acids, phenols, tarry products, sulphur, etc., the acid removing some, while the caustic soda removes the remainder and neutralizes the acid left in the oil.

During the purification process the oil is agitated by mechanical apparatus or by air blast to aid the chemical action. After settling in tanks the commercial products are ready for delivery. These remarks are of necessity very general, as the processes vary in the different refineries. The principles, however, are the same in all cases. Instead of introducing superheated steam into the still, the still may be kept at a low pressure by the "vacuum process" of distillation. In this case the petroleum is distilled under a partial vacuum which is obtained by an ejector form of exhauster, or by designing the still with a long vertical exhaust pipe running downward from the still. Condensers are of various types, the commonest being of the coil type. The distillate is carried through a spiral or parallel tube coil of large condensing surface, the coil being cooled by water circulated around it.

"Cracking." The "cracking process," which was an accidental discovery, revolutionized the method of kerosene production. It is generally employed to increase the production of kerosene from a given amount of petroleum. It is now generally understood that the products of fractional distillation are not identical with the hydrocarbons in the crude oil, but, in part, are the result of chemical reaction during distillation. During the redistillation of the fraction containing lubricating oil, etc., the temperature is carried higher than the normal boiling point of kerosene. The result of this is that the heavier oil undergoes a partial dissociation into specifically lighter hydrocarbons of lower boiling points. These, when condensed, form a commercial kerosene.

Temperatures at which the Fractions Distill. If the process were carried out in a laboratory to obtain the distillation temperatures

of the different petroleum products the results would be somewhat as shown in the table below:

Temp. (Fahr.)	Distillate.	Per cent.	Specific gravity.*	Flash point.* (Fahr.)
118-140°	Petroleum ether.....	Trace.	.6	...
140-160	Gasoline.....	2	.85	10
160-250	Benzine, naphtha } commercial	10	.70	14
250-350	Kerosene, light.. } gasoline..			
350	Kerosene, medium.....	35	.80	150
400	Kerosene, heavy.....	10	.89	270
482	Lubricating oil.....	10	.905	315
...	Cylinder oil.....	5	.915	360
...	Vaseline.....	2	.925	...
...	Residue.....	16
		100		

* Approximately mean values.

The nomenclature applied to the petroleum products throughout the world is so varied as to become confusing, benzine, naphtha, gasoline and kerosene being used very indiscriminately. For simplicity we might divide those products used in the internal combustion engine as fuel into (1) commercial gasoline and (2) kerosene and the heavier petroleum distillates.

1. COMMERCIAL GASOLINE

All figures relative to the boiling point, specific gravity, composition, etc., must be comparative, for naturally the product varies with the field of production of the original crude oil. Approximately the range of distillation temperatures for commercial gasoline is 115° to 350°. At the lower temperature gasoline is distilled off, then, as the temperature is increased, follow benzine, naphtha and light kerosene in the order named. Commercial gasoline may contain any or all of these fractions. Its specific gravity varies from 0.65 to 0.75, depending upon the proportions of *C* and *H* in its composition and it weighs about 5.9 pounds per gallon. The analysis of an ordinary sample shows *C* 85 per cent, *H* 14.8 per cent, impurities (principally *O*) 0.2 per cent. Its thermal value is roughly 20,000 B. T. U.

The standard test for commercial gasoline is its specific gravity. Obviously this criterion is erroneous as the ultimate value of gaso-

line as a fuel depends upon its volatility. For instance, a high-speed engine needs a light fuel, easily volatilized, while a heavy duty, slow-speed motor can use a much heavier fuel. Were the entire supply of gasoline derived from one field, fractions obtained at the same temperatures would always have the same composition and hence the same specific gravity. But, as the world's supply is obtained from many fields in which the compositions vary, it is possible to obtain two gasolines of widely differing specific gravities, which would distill at the same temperature and which might be of equal value as fuels. The volatility of two gasolines being equal, the heavier is more efficient due to the presence of a higher percentage of carbon. This might appear paradoxical from the thermal view, but is based upon thermo-chemical considerations.

At present gasoline holds the internal combustion engine field as the most important of the petroleum products. To prepare gasoline for combustion it must be vaporized, and the ease with which this is accomplished gives it a decided advantage over all other liquid fuels. This fuel is vaporized or volatilized by passing air over or through the liquid, or by spraying the liquid into the air by force or suction. This process, called carburetion, will be treated in a later chapter.

2. KEROSENE

The next heavier distillate after gasoline is kerosene. This is given off at 350° F. to 400° F. and has a specific gravity ranging from 0.78 to 0.82. The composition of a test sample might run *C* 85.1 per cent, *H* 14.2 per cent, *O* 0.7 per cent. Its heating value is about 20,000 B. T. U. and its flash point is between 100° F. and 125° F. It is safer to handle and stow than gasoline, and being less volatile does not deteriorate so rapidly.

It is not so widely used as an internal combustion engine fuel as is gasoline, for at ordinary temperatures it does not form an explosive mixture with air, and to render it a suitable combustible requires special treatment, such as introduction into a heated vaporizer, or spraying into a heated cylinder. This will be treated at length under carburetion. The introduction by one of the popular

motor-car makers of a carbureter which will handle either gasoline or kerosene may do much to bring it before the layman.

1. The Heavier Distillates. Fuel oils have a specific gravity of 0.80 to 0.89 being of a thick consistency, have a high flash point, and have a heating value of 17,000 to 19,000 B. T. U. This is the fuel used in what are known as oil engines. It must be sprayed into the hot cylinder or vaporized in a heated vaporizer. Heat is imperative for its conversion to vapor as it will not form a combustible vapor at ordinary temperatures.

2. Crude Oil. Crude oil is the same thing as petroleum and has been described under that head. It is used in some motors, notably the Diesel engine, by spraying it into the cylinder which is partially filled with heated highly compressed air.

B. ALCOHOL

Although there are over twenty compounds known to the chemist as alcohols, the most important as a fuel is ethyl alcohol, expressed by the formula C_2H_5OH . Being a fixed compound its characteristics cannot vary as in the case of petroleum products. Absolute alcohol, that is 100 per cent pure, has a specific gravity of 0.7946 at 15° C. and 1 gallon weighs 6.625 pounds. Its great affinity for water militates against the commercial article being very pure.

Until a few years ago, a high internal revenue on the manufacture of the article prohibited its use as a fuel in this country. Congress then removed the revenue upon the article if "denaturized" and it is now beginning to take its legitimate place in the fuel field. This denaturizing process consisted of adding to the ethyl spirit a fixed amount of methyl or wood alcohol to render it undrinkable, and a small percentage of benzine to prevent the re-distillation of the ethyl spirits. Congress prescribed the following formula: 100 volumes 90 per cent ethyl alcohol, 10 volumes 90 per cent methyl alcohol, and $\frac{1}{2}$ volume approved benzine. Benzine raises the thermal value of the mixture. One of the denaturizing agents required by the laws of some countries is benzol. This benefits the fuel by neutralizing the formation of acetic acid in the cylinder during combustion.

As noted above, alcohol is rarely found free from water and is therefore designated by its percentage of purity, thus, "90 per cent alcohol" indicates the presence of 10 per cent water. Pure alcohol has a thermal value of about 11,660 B. T. U. and of course the presence of water reduces this value. From this it might be erroneously concluded that its thermal efficiency as an internal combustion engine fuel is lower than that of gasoline. On the contrary its thermal efficiency is higher, as alcohol can be more highly compressed, and the dissociation of its contained water seems to aid the expansion stroke. If equal weights of petroleum and alcohol are completely burned in two motors, the latter will require less air than the former, and consequently the heat losses in the exhaust gases are less per pound of fuel in the alcohol motor. An average thermal efficiency of gasoline in a motor is about 15 per cent. The thermal efficiency of alcohol under some test conditions has reached 28 per cent and 30 per cent. The principal cause of this greater efficiency is the higher compression permissible. These are extreme cases, however, and must not be taken as criterions.

Alcohol is less volatile than gasoline and is easier to handle than kerosene. It requires a special form of vaporizer for it will not form a combustible mixture with air at ordinary temperatures. Heat is employed to aid in its vaporization as will be shown under carburetion. When the cost of alcohol is sufficiently reduced, and this time is in sight, it will compete advantageously with gasoline.

3. The Gaseous Fuels

A. OIL GAS

Gas is generated by vaporizing crude oil by one of two distinct methods, (1) the Pintsch method, and (2) the Lowe process. At present it is used more extensively as an illuminating gas than as a gas engine fuel. It is largely employed for municipal lighting, and everybody is familiar with the Pintsch light of railroad cars.

1. By the *Pintsch method* oil is led through a retort which is externally heated. A thin film of oil is kept in contact with the heated surface and is thus volatilized into a fixed gas. It varies considerably in composition depending upon the original crude oil,

being a mixture of hydrocarbons and free hydrogen. Gülder gives one formula 17.4 per cent C_2H_4 , 58.3 per cent CH_4 , 24.3 per cent H by volume.

2. The *Lowe process* employs a fire-brick lined furnace containing a checker board form of grating made of fire brick. This grating is heated to a very high temperature by an oil-air blast. When the desired temperature is reached, the blast is shut off and the chimney is closed. An intimate mixture of crude oil and superheated steam is now sprayed on to the hot grate and (air being excluded) this mixture is volatilized into an oil-water gas. The grate must be reheated periodically. The analogy to the manufacture of water gas is apparent. In addition to the hydrocarbons generated by the Pintsch method we have N , O and CO in small quantities in gas made by this method.

The process of generation being completed by either method, the resulting product is washed, scrubbed and purified by the usual method (see gas producers). Although the heating value per cubic foot of Pintsch gas is nearly 40 per cent greater than that made by the Lowe process, if based upon fuel consumption required for manufacture, their thermal values are nearly equal.

B. ILLUMINATING GAS

This gas is a mixture of H , CO , CH_4 and other heavy hydrocarbons, O , N and CO , given up by bituminous coal when it is heated in a retort, air being excluded. The residue is coke, tar and ammonia liquor. Part of this coke can be utilized to heat the retort. One ton of coal will give off about 10,000 cubic feet of gas. Its composition necessarily varies widely, dependent upon the coal used and the temperature of volatilization. Its heating value, which varies with the composition, is about 600 B. T. U. per cubic foot.

C. COKE OVEN GAS

When coal is coked in a retort the resultant volatile products are similar to illuminating gas. Hiscox says "in the Connellsville District about 300,000 tons of coal are coked per week. The surplus gas from the coal would develop 366,000 effective horse-power

continuously." As this gas is suitable for gas engine use the great possibilities of developing industries utilizing gas engine power cannot long go unrecognized in districts where coking is carried on.

Modern generation of illuminating and fuel gas may be illustrated by the practice of the United Coke and Gas Company, of New York. For a coking period of 25 hours, the gas given off is divided as follows: During the first 10 hours illuminating gas is formed, it having a high illuminating value and a high heating value of 720 B. T. U. per cubic foot; thereafter fuel gas is formed, having a heating value of but 560 B. T. U. per cubic foot.

D. BLAST FURNACE GAS

The production of pig iron is accompanied by the combustion of coke. The gas evolved during this process can, after suitable purifying, be used as a gas engine fuel. It contains about 5 per cent H , 27 per cent CO , very small quantities of CH_4 and O , considerable CO_2 and about 60 per cent N . Hence its heating value is very low, being about 100 B. T. U. per cubic foot. Its field of use is limited to iron-making districts. Heavy duty motors, of large capacity, are manufactured especially to utilize this heretofore waste product. Blast furnace gas requires a high compression to facilitate ignition and combustion. The reason for this will appear later.

E. NATURAL GAS

Natural gas is found in or near all oil fields. It is obviously a volatile product of oil in a natural state. Many towns light, heat, and receive power from this source. Its use as a gas engine fuel has been developed more rapidly in this country than abroad. Its composition varies with the well, and even the same well may give different results at different times. Hydrogen and hydrocarbons are its principal constituents. The continued supply is rather uncertain in any given district. Excessive H might cause pre-ignition but, when not too high in H , it is an excellent gas engine fuel. Notwithstanding the fact that it has a very high heat value, it does not develop as much power as gasoline vapor, which has a lower heat value but a higher rate of flame propagation.

F. ACETYLENE

Acetylene, C_2H_2 , has been used experimentally in internal combustion engines. Its temperature of ignition is low and since it will ignite spontaneously at low pressures it is unsuitable for use in a high compression engine. It has a high heat value of about 18,000 B. T. U. per pound and having a high temperature of combustion and a high rate of flame propagation the energy derived from it is high. Its cost of production precludes its competition with other fuels at present. Liquid acetylene has been suggested as a possible fuel, but, as yet, extensive experiments have not been conducted along this line.

CHAPTER II

GENERAL

An **internal combustion engine**, as the name implies, is one in which, in counterdistinction to the steam engine, combustion of the fuel takes place in the cylinder itself. A steam engine cannot run without a separate unit, the boiler, for the consumption of fuel and generation of steam, the medium of motive power. Hence in the gas engine vernacular it is called an *external combustion engine*. On the other hand fuel is fed directly to the cylinder of an internal combustion engine, ignited therein, and the resulting explosion acting on the piston furnishes the motive power.

The internal combustion engine is commonly, though erroneously, called an explosion engine. The action which takes place, and which appears to be an explosion, is in reality a progressive combustion and subsequent expansion of the products of combustion. Some oil engines actually carry the combustion through a considerable part of the stroke. Although the expansion line of an indicator card is necessarily of interest to the manufacturer, the ratio of expansion presents no problem, for the internal combustion engine has no adjustable cut-off and therefore the ratio of expansion is fixed for a given engine by the clearance space and the space swept by the piston during its stroke.

The problem of expansion is replaced by questions of rate of combustion, rate of flame propagation, quantity and quality of fuel, and most important of all, *compression*.

The question of compression will be treated at length later, but a word here is necessary to what follows: when a fuel, such as gas, is admitted to the cylinder of an engine, a certain quantity of air is admitted at the same time to furnish the necessary oxygen for combustion. Before ignition this "*mixture*," as it is called, is *compressed* into a small space (the "clearance space"). This

compression serves to mix the particles of air and fuel more intimately and to raise the temperature of the mixture. The resultant compressed mixture will ignite with more certainty and will burn more evenly than a rarer and colder mixture.

There are four essential systems to every internal combustion engine and these are treated at length in subsequent chapters. They are: (1) fuel system; (2) ignition system; (3) cooling system; and (4) oiling system.

Fuel System. This consists of a fuel tank or source of supply, a strainer for liquid fuels, the carbureter, atomizer, or other agent for converting the fuel to a combustible vapor, and the exhaust, which usually terminates in a muffler. In the case of liquid fuels

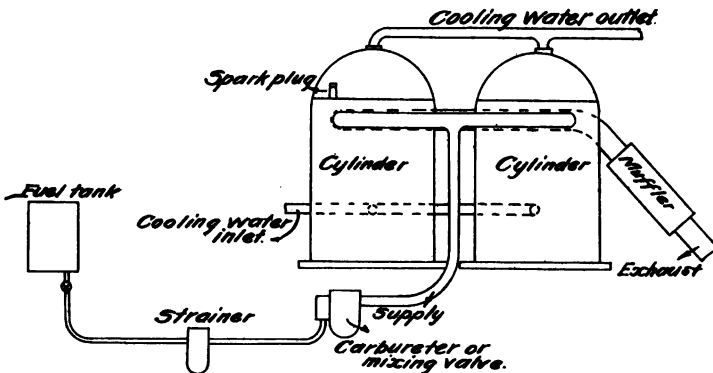

FIG. 3.—Schematic Plan of Marine Gasoline Engine Plant.

it is necessary to volatilize them and mix with air before they can be ignited in the cylinder. Fig. 3 illustrates an ordinary gasoline fuel system.

Ignition System. If the ignition is electrical, this system consists of a source of current supply, wiring, and a means of causing a spark to leap a gap, thus forming an arc in the presence of the fuel in the cylinder. The spark thus created ignites the mixture. If the system is not electrical, then it consists of an apparatus designed to bring the combustible mixture in contact with a surface hot enough to ignite it. This is treated in detail under the chapter on ignition.

Cooling System. This consists of artificial means for keeping the cylinder from overheating and is discussed at length under its own heading.

Lubrication System. This is more complex than in the case of the steam engine, as it is always necessary to include in the system means of lubricating the inside of the cylinder. It is divided into internal and external lubrication as discussed in a later chapter.

Heat Balance. A table accounting for the heat furnished to an internal combustion engine is called the heat balance. From the diagram Fig. 4, such a heat balance might be constructed. Generally the heat is accounted for under four items:

1. Heat of indicated work.
2. Heat loss to circulating water.
3. Heat lost in exhaust gases.
4. Heat of radiation, conduction, etc.

Such a balance for the engine under consideration would be:

Heat converted into mechanical energy.....	22.7%
Heat lost to circulating water.....	24.0%
Heat lost in exhaust gases.....	33.3%
Heat lost by radiation, conduction, etc.....	20.0%
	100.0%

Items one and two can be determined accurately. The determination of item three is difficult and involves the weight of the exhaust gases and their specific heats at the temperature of the exhaust. Item four is the difference between the heat supplied and the sum of the other three items. Sometimes the heat balance is made up of three parts by combining items three and four.

Comparison of the Internal Combustion Engine and the Steam Engine. From the point of efficiency based upon the per cent of heat in the fuel that is converted into mechanical energy, the steam engine shows an efficiency of from 5 per cent to 10 per cent, and the internal combustion engine shows an efficiency of from 17 per cent to 30 per cent. Fig. 4 shows the principal heat losses in the two plants.

Although the engine itself is in many cases heavier per horse power than a steam engine, still the internal combustion engine plant is simpler, more compact, and lighter than the steam plant due to the absence of a boiler. Other advantages are:

1. Easier to start and stop; warming up not necessary, and the engine is ready for a full load after a few revolutions.
2. No radiation or leakage losses in boiler and piping as in the steam plant; no "stand by" losses.

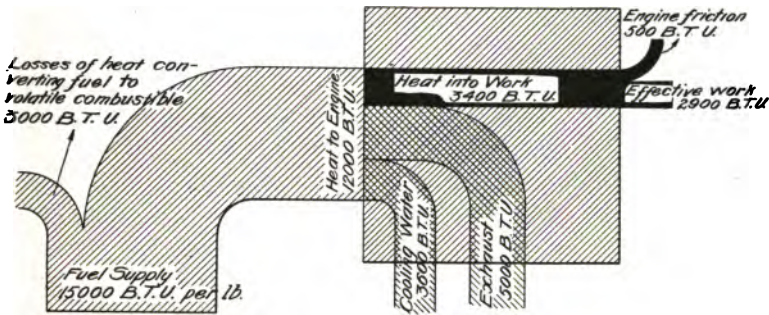

Internal Combustion Engine Plant.
Diagram of Heat Losses per lb. of Fuel.

$$\text{Overall Efficiency} = \frac{2900}{15000} = 19.3\%.$$

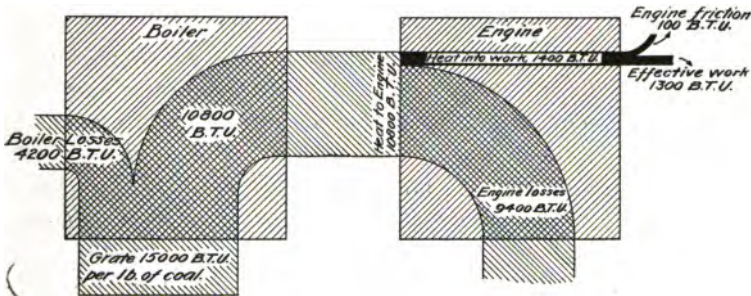

Steam Engine Plant.
Diagram of Heat Losses per lb. of Fuel.

$$\text{Overall Efficiency} = \frac{1300}{15000} = 8.7\%.$$

FIG. 4.—Distribution of Heat Energy in Steam and Internal Combustion Engine Plants.

3. Few auxiliaries; reduced labor and attendants.
4. High pressure present only in the cylinder, which is the part specially designed to withstand pressure.

The disadvantages, in comparison with the steam plant, are:

1. Waste of heat in the exhaust gases. Up to date, the internal combustion engine has not been compounded successfully, and the utilization of this exhaust heat is still an unsolved problem.

2. Whereas the steam engine cylinder is kept at as high a temperature as possible to prevent liquefaction, this does not hold in an internal combustion engine. A large amount of heat must be absorbed by the cooling water to prevent overheating and injury to the cylinder. It is found that, roughly speaking, the maximum efficiency is obtained if the circulating water is kept as near the boiling point as possible.

3. The internal combustion engine is not as uniform in its impulse and speed as the steam engine and until recent years has not been considered as reliable. This has been due in part to ignorance on the part of operators, and it is safe to assume that a good internal combustion engine *per se* is as reliable as a steam engine. Recent developments in governing have given such a uniform speed that alternating current generators in parallel are driven by some of the gas engines on the market.

The ideal condition of an impulse per stroke, which is present in the steam engine, is not attained in the internal combustion engine except in one case, that of the double acting tandem engine which cannot be used for all kinds of work. Only one impulse is received for each two or four strokes in a single cylinder engine, and the engine must be multicylinder to get a continuous impulse. Six cylinders is the least that will furnish an overlapping impulse if the engine be four cycle.

The rapid strides in the development of the internal combustion engine are due quite as much to the demands of the sporting as of the industrial world. The automobile industry has developed the high-speed motor to such a point that there is little improvement in sight. The aeroplane was made possible by the gasoline engine. All the other problems of human flight were solved years before suitable

motive power was available. On the other hand, the industrial world was not behind in developing the slow-speed, heavy-duty motor, and we now find internal combustion engines employed for every conceivable duty from aeroplane propulsion to furnishing the motive power for agricultural machinery.

For marine use, gasoline and oil engines have shown their efficiency in small units, such as launches, torpedo-boats, etc., and recently internal combustion engine installation on ships as large as 8000 tons seem to have been attended with success. Recently much foreign discussion has been raised about installing a plant as main engines on a first-class cruiser or battleship, but no reliable information in support of this can be obtained. It is possible that some foreign government will install a 17,000 horse-power plant of the Diesel type.

From the foregoing balance of advantages in favor of the internal combustion engine, and from its remarkable overall efficiency it must not be concluded that this type engine will ultimately supplant the steam engine and turbine. In a coking region or blast furnace plant, where a fuel supply is obtained from an otherwise waste product, there can be no question of its supremacy, but for marine use there are several inherent difficulties to overcome.

Probably the most important of these is the fact that an oil engine run continuously for more than twelve hours is subject to deterioration due to metallic disintegration of cylinder walls from severe vibration in the presence of intense heat. Since the oil engine is the logical type for marine use it would appear that there are still unsolved problems to be dealt with, and experiments now underway may produce wonderful results in the near future.

As early as 1862 Beau de Rochas announced the four requisites for economical and efficient working of internal combustion engines, and, with one exception, these are undisputed to-day. They are:

1. The greatest possible cylinder volume with the least possible cooling surface.
2. The greatest possible rapidity of expansion. Hence, high speed.
3. The greatest possible expansion. Hence, long stroke.

4. The greatest possible pressure at the beginning of expansion. Hence, high compression.

Of course the type of motor must depend upon the particular work it is intended to perform. Much discussion has arisen on the merits of the long or short stroke motor. The long stroke gives a greater expansion, but it also increases the duration of contact of the gases with the cylinder walls, hence increasing the radiation losses, etc. The short stroke decreases the expansion, but it also decreases the radiation losses. This point must be settled by other considerations arising from the particular duty that the motor will perform.

CHAPTER III

CONSTRUCTION

The subject of internal combustion engine construction will have to be treated in a very general manner because of the variety of forms of all the parts found in different types. Naturally the design of engine depends upon the service it is intended to perform, thus, the aeroplane engine has been constructed to weigh as little as two pounds per horse-power, whereas engines for marine use

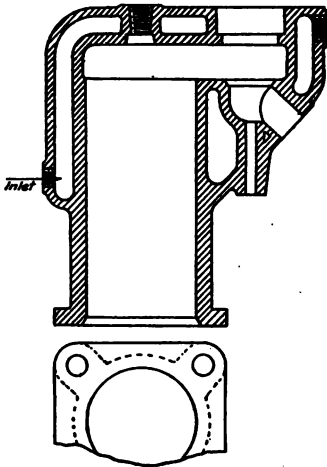

FIG. 5.—Water Cooled, Four Cycle Cylinder.

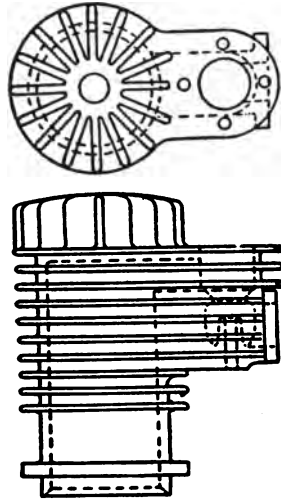

FIG. 6.—Air Cooled, Four Cycle Cylinder.

weight from 45 to 60 pounds per horse-power. With the many types existing it is only possible to give a few general forms of parts.

Cylinder. Cylinders may be cast singly or *en bloc*, that is, in a multicylinder engine each cylinder may be cast as a separate unit or two or more may be cast in one piece. They are generally classified as (1) water cooled and (2) air cooled, depending upon the system adopted to prevent overheating of the cylinder. Fig. 5

shows a water cooled cylinder with the annular space in which to circulate water. Fig. 6 shows an air cooled cylinder. The ribs cast on the outside of this cylinder increase the radiating surface of the cylinder and thus serve the same purpose as the circulating water in the other type. It should be noted that the annular space and the ribs do not extend the full length of the cylinder, but only cover the upper part. They only extend a little below the compression space which is the hottest part of the cylinder as will appear later. Fig. 7 shows a water cooled cylinder with a copper

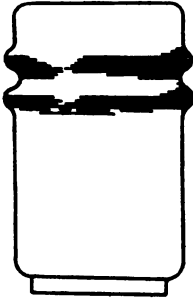

FIG. 7.—Copper Jacketed Cylinder.

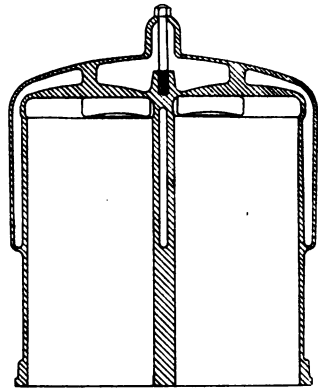

FIG. 8.—Pair of Cylinders Cast *en bloc*.

water jacket fastened and caulked to the cylinder. The corrugations shown allow for the unequal expansion of the copper of the jacket, and the iron of which the cylinder is cast. This construction is the more expensive of the two and is only used in automobile and aeroplane engines. Fig. 8 illustrates a pair of cylinders cast *en bloc*.

Cylinders are made of close grain, gray, cast iron, hardness being the essential requisite. The previous four illustrations portray the four cycle type engine; Fig. 9 shows the general type two cycle cylinder without valves; the piston passing over the port openings acts as a valve. The cylinders are counterbored at the end of the

stroke. This prevents the formation by the ring of a collar at each end of its travel.

Piston. The majority of internal combustion engines are single acting, receiving the impulse on only one end of the piston. The impulse is much more sudden than in the case of the steam engine, and if the piston were constructed disc shaped, as in the steam engine, there would be a tendency to cant or dish on the explosion stroke. For this reason and for the purpose of aiding packing, cooling and guiding generally, the piston is made long and hollow, the

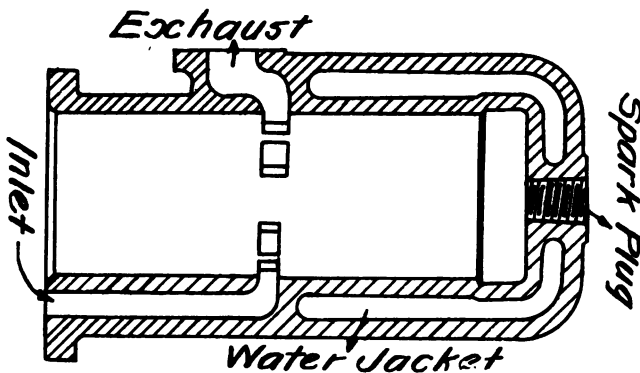

FIG. 9.—Two Cycle Water Cooled Cylinder.

length for a good four cycle, high-speed design being about one and one-half times the diameter. In this type the length precludes the necessity for connecting rod and guides. The piston tapers, the explosion end being slightly smaller, say .001 of the diameter, than the opposite end. The reason for this is that the explosion end, being in contact with the hot gases, when running, will expand more than the other end. It is fitted with eccentric rings, usually four, which spring into grooves shown in Fig. 10, the lowest ring acting as an oil ring. Fig. 11 shows a piston with rings, connecting rod and bearings, all assembled. Heavy duty and double acting engines have different types of pistons, some being of such a form as to require piston rod, connecting rod and guides. These are illustrated in Chapter X.

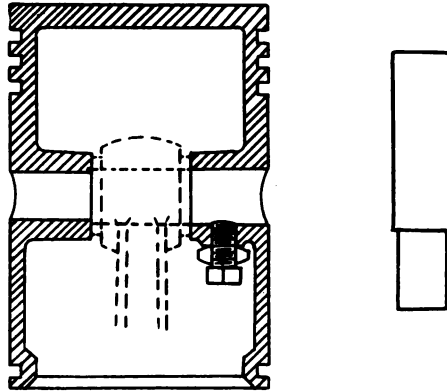

FIG. 10.—Piston, Showing Method of Securing Connecting Rod.

Figs. 12 and 13 are two types of piston heads for two cycle engines. The dished head, Fig. 12, and the web cast on top of the piston, Fig. 13, serve to deflect the incoming gases and thus aid in scavenging the cylinder.



FIG. 11.—Piston with Rings, Connecting Rod and Bearings Assembled.

Connecting Rod and Wrist Pin. In all engines, except the large stationary ones, the piston rod is absent, the piston motion being communicated to the crank direct by the "connecting rod." At the piston end the rod is connected to the "wrist pin." There are two ways of forming this bearing; first—the one most commonly used—the wrist pin is locked fast to the piston, the rod working on it; and second, the rod is locked fast to the wrist pin and the pin works in the piston as a bearing. Fig. 10 illustrates the

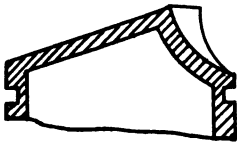

FIG. 12.

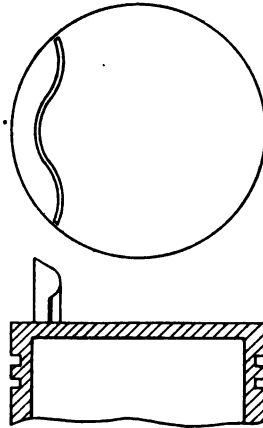

FIG. 13.

Two Cycle Piston Heads.

first method, a set screw and lock nut being shown in place. Rods are forged or drop forged steel, the heavy stationary engines having rods of rectangular section and the marine and lighter engines having an "I" section rod.

Valves. The most common and best developed valve at present is the disc, poppet valve shown in Fig. 14. Drop forged valves answer the purpose for all but the heavier engines which require valves cast in one piece. The best material must be used in valves, especially the exhaust, as they are subject to the intense heat of explosion, and the exhaust valves receive the full corrosive effect of the fast moving, hot exhaust. The smaller valves have a slot in the head to fit a screw-driver or tool for regrinding to the seat.

The requirements for an efficient valve are: (1) it must be gas tight without excessive friction; (2) the opening and closure must be instantaneous; (3) it must be accessible for cleaning, grinding, etc.; (4) the gases must not be wire drawn. The exhaust valve is generally actuated by cam gear situated on a countershaft that is geared to the main shaft. This is also the better method for actuating the admission valve, although some engines are fitted with spring loaded admission valves that lift automatically on the suction stroke. In some designs a rod and rocking lever, actuated by a cam, opens alternately both admission and exhaust valves of the same cylinder. The Curtis engine and many motorcycle engines are of this type.

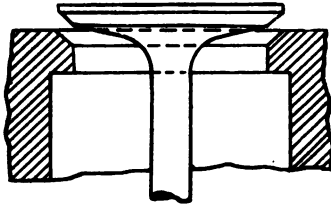

FIG. 14.—Conical Disc, Poppet Valve.

There are a variety of novel valves, such as rotating valves, that have not received general recognition. The Knight motor has two reciprocating sleeves between the piston and the cylinder. These sleeves contain openings that cover and uncover the port openings at the proper points of the cycle and thus act alternately as admission and exhaust valve. The larger exhaust valves are hollow to permit circulation of water for cooling the valve.

Push Rods. Interposed between the valve stem and the cam on the countershaft is a push rod, Fig. 15. As seen in Fig. 20 these are carried in guides that fasten to the engine base. On the lower end is a hard steel roller that bears on the cam giving a minimum friction. In the latest practice for high speed engines the top of the push rod has an adjustable screw that bears on the valve stem so that wear on the end of the rod can be compensated; this tends toward quiet running, and aids valve timing.

Fly-Wheel. On account of the intermittent impulse given an internal combustion engine shaft, all engines having six or less *working cylinders* require a fly-wheel. By its inertia it tends to give a uniform rotation to the shaft in spite of the non-uniform crank effort. Obviously, the relative size of fly-wheel required increases with the decrease in the number of working cylinders. The same features govern fly-wheel design whether for internal combustion or other engines, except that more care must be taken in the balance of those used in this particular field.

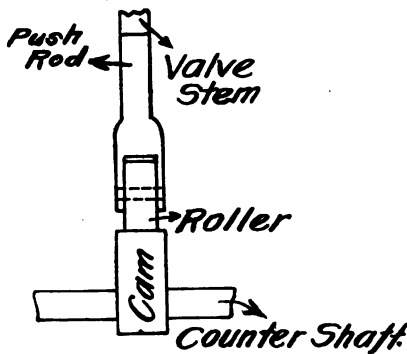

FIG. 15.—Push Rod.

Balancing the Crank Arm. Single-throw cranks for high-speed engines are provided with balance weights to balance the weight of the crank pin, web, and that part of the connecting rod that is regarded as rotative. These weights are generally located on both crank webs, and must be securely fastened, because any play between them and the web would rapidly increase from the engine vibration and would cause serious trouble.

Muffler. For quiet operation the muffler is an essential part of the exhaust system. Exhausting into the atmosphere at the normal exhaust pressure causes a sharp disagreeable noise. This is so annoying that many municipalities have passed ordinances requiring that all internal combustion engines be fitted with mufflers.

A muffler is merely an enlargement near the end of the exhaust line to allow a gradual expansion of the exhaust gases to the at-

mospheric pressure. Though there are a variety of forms, the principle is the same in all. Cast iron is generally used in construction as this best resists the corrosive effects of the hot gases.

Some mufflers are fitted with baffles, and in this case care must be taken in the design to prevent a back pressure in the exhaust. A properly designed muffler will reduce the pressure at the muffler exit without reducing the speed of the exhaust from the engine to the muffler. As long as this speed is maintained no back pressure will result. In stationary plants water spray is sometimes injected

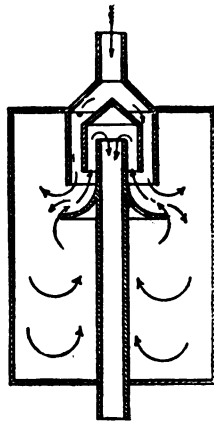

FIG. 16.—Thompson Muffler.

into the muffler to condense the gases. This is a common marine practice.

The Thompson Muffler, Fig. 16, best illustrates the muffler principle. This consists of a cylindrical chamber with a hooded inlet pipe of increasing volume. The exhaust puffs pass into a large chamber where they expand and pass out of the exit pipe in a steady stream of practically constant pressure.

The gas pipe muffler, Fig. 17, operates on the same principle as the Thompson, but is of a cruder design.

The ejector muffler, Fig. 18, is designed as its name implies, on the principle of an ejector. It consists of three expansion chambers

which are formed by conical baffle plates, perforated top and bottom, arranged in two sets. The axial tube, leading through the muffler, is of varying diameter and a part of the gas entering the muffler passes directly into the center chamber and through the second set of cones before the gas which has entered the first chamber has

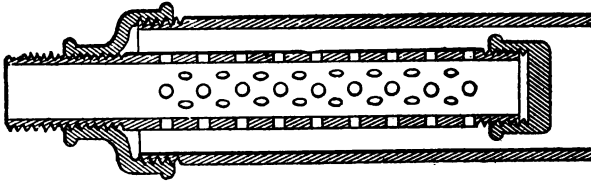

FIG. 17.—Gas Pipe Muffler.

passed through the first set. A portion of the gas is conducted straight through the center pipe to the nozzle at a high velocity which creates a partial vacuum in the third chamber. The rapid forward movement of the gas through the first and second chambers to the third, causes a sudden expansion, removing the heat from



FIG. 18.—Ejector Muffler.

the gas and reducing the pressure in the muffler to below that of the atmosphere. This allows the gas to escape without noise and without back pressure. Water may be used in this type, and it is very suitable for marine use.

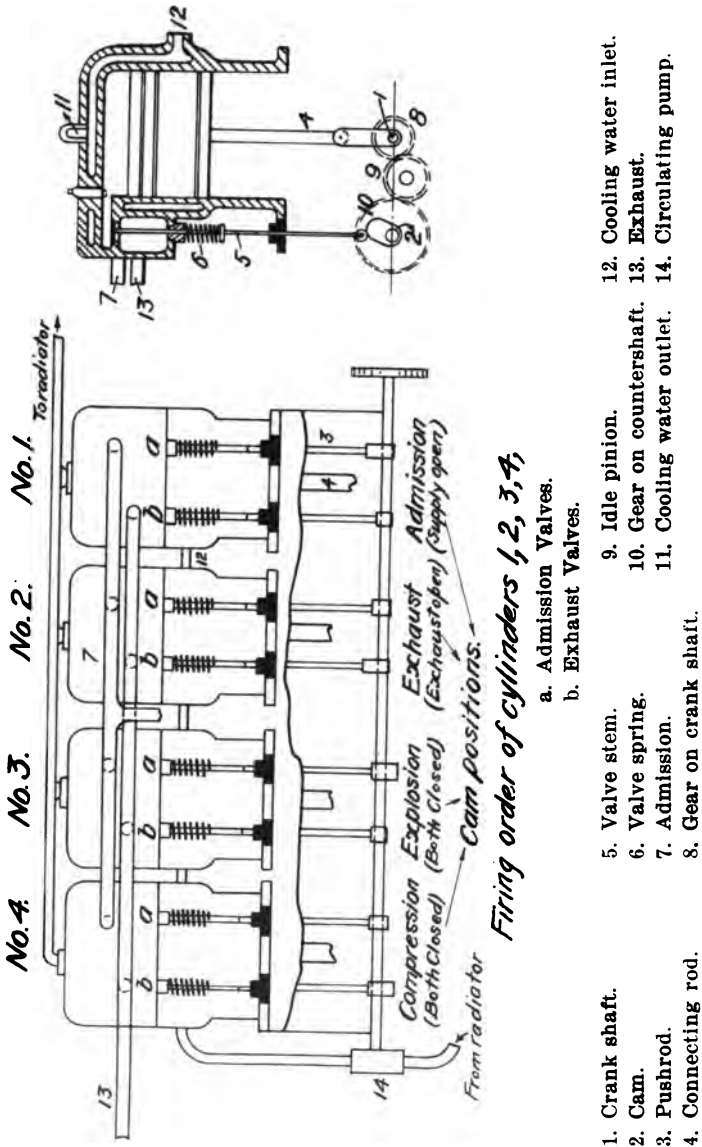

FIG. 20.—Counter Shaft, Illustrating Cam Positions.

Firing order of cylinders 1, 2, 3, 4

a. Admission Valves.
b. Exhaust Valves.

- 1. Crank shaft.
- 2. Cam.
- 3. Pushrod.
- 4. Connecting rod.
- 5. Valve stem.
- 6. Valve spring.
- 7. Admission.
- 8. Gear on crank shaft.
- 9. Idle pinion.
- 10. Gear on countershaft.
- 11. Cooling water outlet.
- 12. Cooling water inlet.
- 13. Exhaust.
- 14. Circulating pump.

Underwater Exhaust. Fig. 19 illustrates a common form of exhaust below the water line. In this case there are two outlets from the muffler. This form is a little more expensive than that with one outlet, but it is used considerably with the ejector muffler.

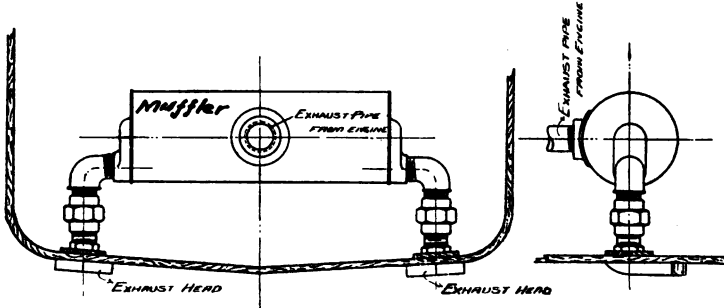

FIG. 19.—Underwater Exhaust.

Countershaft for Multicylinder Engine. In a multicylinder engine where there are numerous valves, etc., to be actuated by cams, a countershaft, sometimes called the cam shaft, is fitted. This is a small shaft, running the length of the engine, parallel to and geared to the engine main shaft. In addition to actuating all the valves this shaft sometimes actuates the timer, pumps, etc. It is geared to the main shaft of a four cycle engine in the ratio of one to two because each operation at any one valve must take place every second revolution. Fig. 20 shows the countershaft as operating in a marine or other high speed engine. It is made of the best nickel steel. Engines designed with admission and exhaust valves on opposite sides of the cylinders require two countershafts.

CHAPTER IV

TYPES, CYCLES, ETC.

Cycles

“A cycle in engineering is any operation or sequence of operations that leaves the conditions the same at the end that they were in the beginning.” An internal combustion engine cycle consists of: (1) suction or admission of the charge; (2) compression; (3) ignition, combustion and expansion; (4) exhaust. The number of strokes necessary to complete this cycle gives a means of cyclic classification as follows: (1) two-stroke cycle; (2) four-stroke cycle. The common terms for these are two cycle and four cycle. The latter is sometimes called the Beau de Rocha cycle, or more commonly the Otto cycle. The two cycle is sometimes called the Clerk cycle.

Four Cycle

Figs. 21 to 24, inclusive, illustrate the four strokes forming a complete cycle in a four cycle engine. The piston is shown near the finish of the stroke in each case.

Admission. In Fig. 21 the piston has traveled one down stroke. During this stroke the admission valve is open and the vacuum formed by the down stroke of the piston has been filled by the inrush of a fresh charge of combustible mixture. This is called the suction or aspiration stroke. The admission valve closes at the end of this stroke.

Compression, Fig. 22. During this up stroke both valves are closed and the charge is compressed into a small space at the cylinder end called the “clearance space.” The necessity for compression will be shown later.

Ignition, Fig. 23. This third stroke is the power stroke and is variously known as the ignition, combustion, expansion, or explosion stroke. During this stroke both valves are closed. At the beginning of the stroke the charge is ignited and the subsequent expansion furnishes the motive impulse to the piston, driving it to the end of its stroke.

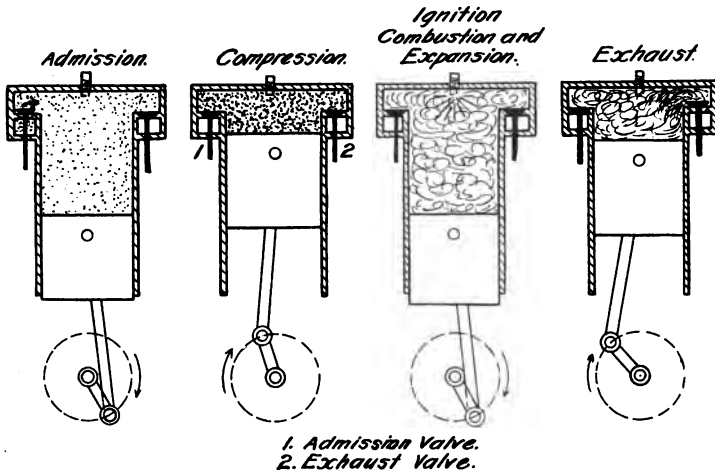

FIG. 21.

FIG. 22.

FIG. 23.

FIG. 24.

Periods in the Cycle of a Four Cycle Engine.

Exhaust, Fig. 24. The exhaust valve opens at or near the end of the expansion stroke and the up travel of the piston on this fourth stroke forces the gases of combustion out of the cylinder completing the cycle.

As the engine receives only one impulse every fourth stroke means must be employed to drive the engine throughout the remaining three. A fly-wheel, which accomplishes this by its inertia, is installed on the main shaft. In the case of multicylinder engines the fly-wheel by its inertia balances the impulses and gives a steady speed.

Two Cycle

The two cycle engine requires only two strokes or one revolution to complete the cycle. As seen from Fig. 25, the crank case is closed gas tight and a spring loaded admission valve opens to the crank case. Instead of the admission and exhaust being regulated by valves, port openings in the cylinder sides are uncovered by the

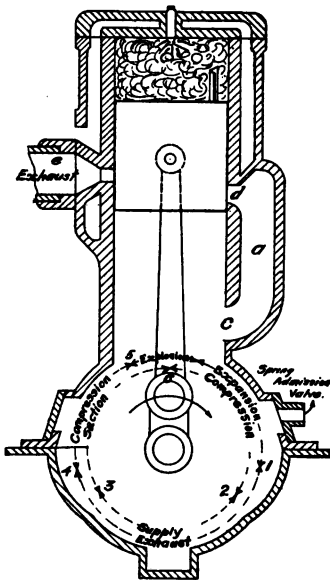

FIG. 25.

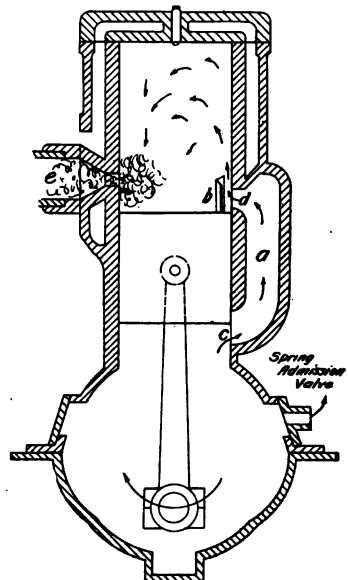

FIG. 26.

Periods in the Cycle of a Two Cycle Engine.

piston at proper points in the stroke and these openings communicate with the fuel supply and the exhaust passage. The piston functions as valves. The port *a*, Fig. 25, connects the crank case and cylinder around the piston, when at the bottom of its stroke. Deflecting plate *b* aids in scavenging the cylinder.

Two circles in the crank case, Fig. 25, illustrate the steps in the cycle. The inner circle indicates operations in the crank case and the outer circle indicates simultaneous periods in the cycle on

top of the piston. Starting from the position shown in Fig. 25, the charge is compressed in the top of the cylinder and has just been ignited. The crank case is full of a fresh charge that has just been drawn through the admission valve. The piston is driven down by the expansion. The port *d* being covered, the charge in the crank case is compressed on the down stroke. Expansion takes place in the cylinder to the point 1 and when this point is reached by the crank, the exhaust port is uncovered relieving the pressure. At the point 2, port *d* is opened allowing communication between the crank case and the cylinder. The compressed charge in the crank case rushes into the cylinder displacing the exhaust gases which escape through the exhaust port *e*, Fig. 26. On the return stroke when the point 3 is reached port *d* is covered by the piston and the up travel of the piston creates a vacuum in the crank case, opens the admission valve and sucks a fresh charge into the crank case. At the point 4 the exhaust port is covered and from this point to point 5 the fresh charge on top of the piston is compressed. At point 5 ignition takes place completing the cycle. At 6 the spring loaded admission valve to the crank chamber closes.

As the piston receives an impulse every other stroke, a fly-wheel is employed to drive the piston through the non-impulse stroke. The two cycle engine is sometimes called a valveless engine on account of the absence of valves.

Advantages and Disadvantages of the Two Cycles.

Two Cycle. *Advantages.* No valves, valve gear, cams and cam shaft; more uniform turning moment and lighter fly-wheel; smaller cylinder volume per unit of power; simplicity and compactness.

Disadvantages. Loss of fresh fuel with exhaust reduces the economy; crank case must be kept gas tight to prevent loss of fuel and compression; fresh fuel entering the cylinder full of hot exhaust gases may cause premature explosion, and if this occurs before the admission port is closed, the crank case charge may explode, causing considerable damage to the engine. For large engines an auxiliary pump is employed to replace crank case compression.

Four Cycle. *Advantages.* Better explosion control; more economical; compression not dependent upon tightness of any part except valves and piston rings; no auxiliary pump required; gas tightness of crank case immaterial.

Disadvantages. Cylinder volume and weight per unit of power greater; multiplicity of parts, especially valves, valve gear, cams, countershaft, etc., with increased probability of breakdown; loss of power if any valves are not gas tight.

The four cycle engine seems to lose in simplicity by comparison with the two cycle, but it is in far more common use.

Although the two cycle engine receives twice as many impulses per revolution as the four cycle, it must not be concluded from this that, for the same cylinder dimensions, the two cycle has twice the power. In the four cycle type the impulse, due to expansion, is carried throughout nearly the entire stroke, whereas, in the two cycle type, the exhaust valve opens much earlier and the impulse only lasts about five-eighths of the stroke, as can be seen from Fig. 25.

Types

The internal combustion engine is commonly called by a variety of names, none of which are technically correct for all types, for example, *gas engines, explosion engines, heat engines, etc.* Two general subdivisions may be made, viz.: (1) single acting; (2) double acting.

A single acting engine is one which receives the motive impulse on only one side of the piston.

A double acting engine is one which receives the motive impulse alternately on both sides of the piston.

All of the small high-speed engines are single acting, and, with a few exceptions, only the large, low-speed, heavy-duty motors are made double acting.

A very common and unscientific method of classifying internal combustion engines depends upon the fuel consumed, thus, gas engine, gasoline engine, oil engine, alcohol engine, alco vapor engine, etc. This a common commercial practice.

The only scientific classification is a thermodynamic one. Heat is imparted to the fuel and medium by the chemical reaction that follows ignition. The method of applying this heat to the working substance determines the class in which the engine belongs. The classification is as follows:

1. Engines receive heat, the charge being at constant volume.
2. Engines receive heat, the charge being at constant pressure.
3. Engines receive heat, the charge being at constant temperature.

Ignition with Charge at Constant Volume

This class of engine is the one in most common use and is frequently erroneously called an *explosion* engine. The whole charge, which is drawn in on the aspiration stroke and compressed, is ignited, and, the charge occupying a small space, the rate of flame propagation is so rapid that the charge practically burns without change of volume before expansion takes place. In other words combustion is complete before expansion starts. The subsequent rapid expansion, with its accompanying rise of pressure, furnishes the motive power. All engines using gas or *carbureted* fuel ignite at constant volume.

Ignition with Charge at Constant Pressure

This principle was adopted by Brayton in his engine about 1870. He apparently got his idea from the action of the steam engine to which its cycle is analogous. Separate pumps supplied air and combustible to the cylinder at constant pressure and the mixture burned as it entered. The pressure was therefore constant during the expansion or combustion stroke until the admission valve closed. The increased volume at constant pressure drove the piston. This engine, which was at one time popular in this country, is no longer manufactured. The latest Diesel engine manufactured in Germany approaches this principle.

Ignition with Charge at Constant Temperature

The card from an engine built on this principle would have a combustion line which, when analyzed, would prove to be isothermal.

As late as 1904 the American Diesel Engine Company claimed this for their engine. This is rather surprising in view of the fact that isothermal combustion is theoretically the least efficient. It would be possible to construct an engine of the Diesel cycle whereby, air being previously compressed in the cylinder to a very high temperature, the fuel could be injected during the combustion stroke at such a rate as to maintain this temperature. This presupposes a very accurate and minute fuel supply regulation.

It can be shown mathematically that combustion at constant volume gives the most efficient cycle and that combustion at constant temperature gives the least efficient. Combustion at constant pressure gives a cycle which is between these two in efficiency.

Compression

Compression, which immediately precedes ignition, is one of the greatest factors in internal combustion engine efficiency. With a given amount of fuel to be burned, if this fuel were not compressed, the cylinder volume would necessarily be increased by the ratio of expansion and would be enormous were the engine non-compression. This was recognized by the inventors of the first efficient gas engine as the underlying principle of success. Thus it is apparent that compression is absolutely necessary.

By compressing the mixture into a small space the atoms of the fuel are more intimately mixed, thus aiding combustion, and they are brought more closely together thus accelerating flame propagation. Compression heats the mixture, thus aiding ignition and increasing the initial temperature; it also greatly increases the mixture's power of expansion.

By increasing the compression the necessary clearance or compression space is reduced; this reduces the cylinder wall area of radiation and water jacket length and as a direct result the loss of heat by radiation is diminished. Reducing the clearance space is the equivalent of increasing the stroke. If the compression is too low the fuel may not all burn, due to poor flame propagation, and some gases will not ignite at all unless compressed to a certain pressure.

There is a practical limit to the degree of compression that may

be attained. This depends upon the ignition temperature of the fuel. As stated above, compression increases the temperature and, if this is carried too far, premature ignition will result. The following limits in pounds are given by Lucke: Carbureted gasoline, high-speed engine, 45-95; carbureted gasoline, slow-speed, well-cooled engine, 60-85; kerosene, hot bulb injection and ignition, 30-75; kerosene, vaporized, 45-85; natural gas, 75-130; producer gas, 100-160; blast furnace gas, 120-190. The degree of compression that is necessary for efficiency depends upon the ignition point of the fuel, increasing with this temperature.

CHAPTER V
**CARBURETION, THE MIXTURE, ITS PREPARATION,
CARBURETERS AND VAPORIZERS**

Definitions

Carburetion is the process of saturating air or gas with a hydrocarbon.

The air or gas that is carbureted is called the *medium*.

The *carburiizer* is the agent (fuel) employed to saturate the air.

A *carbureter* is an apparatus used to charge air or gas with a volatilized hydrocarbon.

"*The mixture*" is the term commonly employed in the gas engine world to designate the product of the carbureter when ready for combustion, viz.: the combination of fuel and air.

A "*rich*" mixture is one having an excess of fuel, and a "*lean*" mixture is one having an excess of air.

A "*charge*" is a cylinder full of mixture.

Every fuel requires a certain amount of oxygen for complete oxidation or combustion. This can be supplied by the atmosphere if suitable means are at hand to mix the air and fuel. The various fuels contain different proportions of carbon, hydrogen and other combustibles, therefore, will require proportionate amounts of air to attain complete combustion. Excessive air will cool the mixture, greatly reduce the rate of flame propagation, and weaken the ignition if it does not actually prevent it. Its increased volume causes increased loss of heat in the exhaust gases. Too little air will result in incomplete combustion, reducing the efficiency and causing a carbon deposit in the cylinders, etc.

The function of a carbureter or of a mixing valve is to admix the fuel and air to the correct richness, forming a combustible gas or vapor. The rapid advance in the development of the modern internal combustion engine is due in large part to the perfection of

satisfactory apparatus to carburet air. Successful working of such an engine is dependent upon the reliability, certainty, and satisfactory working of the carbureting device. Carburetion cannot be carried on at ordinary temperatures unless the fuel is very volatile. For the less volatile fuels heat is employed as an aid, and in this case carburetion consists of atomization and subsequent vaporization by heat.

The method adopted depends upon the fuel to be used, therefore carburetion will be treated under the following five heads: (1) gas; (2) gasoline; (3) kerosene; (4) alcohol; and (5) oil.

1. Gas. Gas obtained from a city main is ready for use as delivered, but if a pure gas is supplied, it must be prepared for combustion by intimately mixing with air. This may be accomplished by pumping the gas and air together into the cylinder or into the space outside the admission valve. This method is illustrated by the Koerting engine in Chapter X. Another method is to introduce the gas and air into the cylinders through separate valves.

2. Gasoline. This being one of the most frequently used fuels, its carburetion will be treated at length. It may be carried on by three distinct methods, the first two of which have practically fallen into disuse.

a. Surface Carburetion. This, the earliest method used, consists of evaporating the liquid hydrocarbon by passing a current of air over the surface of the liquid. The air thus becomes saturated by evaporation of the liquid from its free surface. This method is practically obsolete for the following reasons: Evaporation from the free surface of gasoline will tend to volatilize the lighter hydrocarbons, leaving a liquid of rapidly increasing density, which finally loses its volatility at ordinary temperatures. The continued evaporation reduces the temperature of the liquid, due to its latent heat, and this also reduces its volatility. Even if fuel be constantly added to the carbureter to replace that evaporated, a uniform mixture is impossible.

b. Mechanical Ebullition. By introducing a current of air below the surface of gasoline and allowing it to bubble to the surface a certain amount of the liquid is entrained as mist in the air. This

method was abandoned also for practically the same reasons as the former.

c. Spray Carburetion. This is the only practical method now employed to convert gasoline into a combustible vapor. Each suction stroke of the piston creates a vacuum in the cylinder, which vacuum sucks the air into the cylinder through the mixing chamber of the carbureter. This air is at a pressure below the atmosphere. The mixing chamber communicates with the gasoline chamber of the carbureter by a fine nozzle or needle valve. As the air passes over this nozzle a spray of gasoline is sucked through it into the passing air which it saturates. This is made more clear by a study of the carbureter itself.

A good carbureter or mixing valve must fulfill the following requirements: It must be adjustable so that the correct proportion of fuel and air is obtained; this proportion must be maintained at varying speeds; if possible, the location of the spraying nozzle should be near the middle of the air passage; and the apparatus must be simple and compact.

The distinction between a mixing valve and a carbureter will be seen from a description of each. In both cases fuel is drawn through a nozzle into the air which is being sucked into the cylinder. A mixing valve has its nozzle below the source of fuel supply and this nozzle is opened and closed by a valve which is lifted at each aspiration stroke of the cylinder. A carbureter has its nozzle just above the gasoline level in the gasoline chamber of the carbureter and the fuel is sucked through the nozzle by the air on each aspiration stroke. In either case the flow of gasoline vapor stops when the engine is stopped.

The Schebler Carbureter, Figs. 27 and 27a. This is one of the most popular and efficient of the high-speed carbureters. The opening marked "gasoline supply" is connected to the gasoline tank by piping. Gasoline enters here and goes to the annular gasoline chamber. It is maintained at a constant level in this chamber by means of a cork float and a float valve connected to this float. The connection is pivoted so that the valve will rise as the float falls. As the gasoline level drops the cork float on its surface drops and this opens

the float valve, allowing gasoline to enter. When the gasoline rises to the proper level the float closes the valve. The upper end of the carbureter, which contains the throttle disc, is connected to the admission pipe of the engine. On each suction stroke air is sucked through the air passage into the mixing chamber. In its course it passes around the spray nozzle. This nozzle passes through the air passage wall and communicates with the gasoline chamber. Each suction stroke, gasoline is sucked through the spray nozzle and mixes with the air in the mixing chamber. The opening of this spray nozzle can be regulated by a needle valve, Fig. 27a. The carbureter is designed so that the air passage will supply enough air at the low speeds. As the speed is increased above this, it is evident that more fuel is sucked through the needle valve and hence more air must be supplied per stroke for combustion. The leather air valve shown on the right, Fig. 27, compensates for this as follows: At low speeds the valve is kept on its seat by the spring. As the suction increases it overcomes the tension of this spring and the valve will lift each aspiration stroke an amount dependent upon the speed. The throttle disc acts as an ordinary throttle, but attachments on the throttle shaft further regulate the fuel supply for the speed. As the disc is opened and more air is drawn through the air passage, it becomes necessary to provide a larger fuel valve opening to supply the increased demand for fuel. This is accomplished as follows: As the throttle disc is opened the cam on the adjusting cam casting is rotated and bearing on the needle valve roller opens or shuts the needle valve simultaneous with the throttle. The needle valve roller moves the needle valve lever and the needle valve about the needle valve lever pin, thus opening and closing the needle valve, Fig. 27a. The cam spring adjusters are used to adjust the cam on the adjusting cam casting so that the needle valve roller pin, and consequently the needle valve, will be opened the proper amount at all speeds. The adjustments are too complicated for a novice to handle. A drain cock, not shown, is generally placed on the bottom of the bowl to drain the gasoline chamber. This prevents the accumulation of water and dirt in the carbureter. All metal parts are of brass. The end of the spray nozzle is in the

center of the column of entering air. This is a point that is overlooked in many otherwise good designs, and tends to maintain a uniform quality mixture for all positions of the carbureter and is of importance in marine practice as well as in motor vehicles.

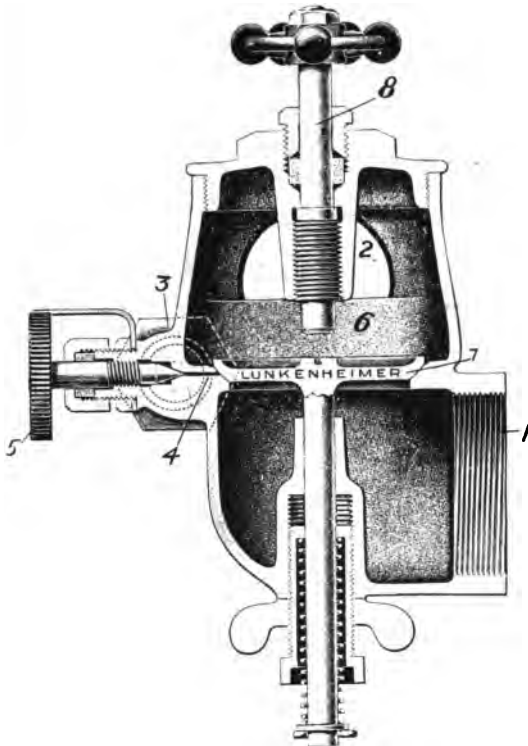

FIG. 28.—Lunkenheimer Mixing Valve.

The Lunkenheimer Mixing Valve, Fig. 28. Air entrance is effected at 1. Gasoline enters at 3 through the needle valve passage 4. The amount of entering fuel is regulated by the needle valve which is operated by the graduated wheel 5. The mixture leaves for the engine at 2, after passing over the baffle 6 which aids the mixing. On each aspiration stroke valve 7 lifts, uncovering the needle valve

passage. Air is sucked to the upper chamber, drawing gasoline from the needle valve. The valve is seated by its spring at the end of the aspiration stroke, and its lift is regulated by the stop 8. Passage 2 contains a throttle.

There are innumerable carbureters and mixing valves on the market and the above are chosen as typical designs.

General. It is advantageous, especially in cold weather, to have the source of air supply warmer than the atmosphere. Many methods are employed, such as having the air suction drawn from the proximity of the hot exhaust pipe, leading the hot exhaust gases around the admission pipe, or jacketing the carbureter with the exhaust gases or heated exhaust circulating water. 80° F. to 85° F. is the best temperature for admission. The temperature and hygrometric condition of the air supply regulate the relative quantities of air and fuel required in the mixture. It will be necessary to regulate the mixture to meet the varying atmospheric conditions.

3. Kerosene. There are two methods of treating this fuel: (a) carburetion, similar to gasoline; and (b) injecting into the cylinder or vaporizer near the air valve, as in the case of the heavier oils.

a. Carburetion of kerosene, as stated before, requires the application of heat to aid vaporization at ordinary temperatures. Therefore, the process consists of two parts, first atomizing the fuel in a similar manner to gasoline carburetion and then vaporizing this spray by heating. This heat is applied either by jacketing the carbureter or admission pipe, or by heating the air before passing the same through the carbureter. Any well designed gasoline carbureter will carburet kerosene if jacketed. Many kerosene carbureters start on gasoline and shift to kerosene after the engine is started and well warmed up. Such a carbureter is similar to the alcohol carbureter shown in Fig. 30.

b. Kerosene may be injected into the cylinder direct and the necessary air supplied by a separate valve. Means are employed to regulate the amount of fuel that is drawn into the cylinder each suction stroke. The passage of fuel through its valve atomizes it, and upon contact with the hot cylinder or vaporizer walls it is vaporized.

The *Crossley vaporizer* (see Fig. 29). Air is drawn into the cylinder by the suction stroke of the engine, through the spring loaded air valve. As this valve lifts, the in-rush of air sucks a kerosene spray through the duct labeled oil measurer. The lamp flame serves to vaporize the atomized kerosene, in addition to heating the hot tube igniter. *c* is the cylinder, and *w* is the water jacket. When running the vaporizer temperature is maintained by the heat of compression.

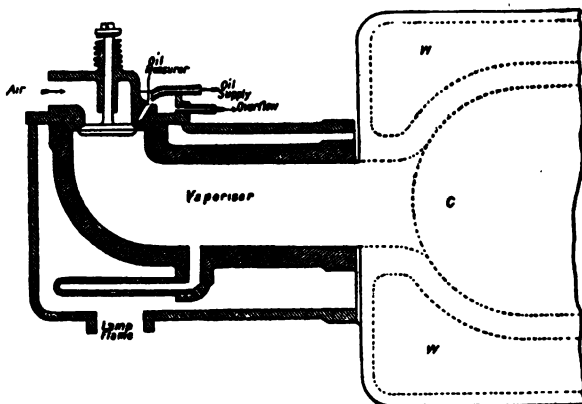

FIG. 29.—Crossley Vaporizer.

4. Alcohol. Correct carburetion of alcohol is more difficult than would be suspected by an inexperienced operator. Excess of air creates increased loss of heat through the exhaust gases and retards ignition, but a deficiency of air causes much more serious trouble. The resulting incomplete combustion causes the formation of corrosive and fouling products which corrode and clog the cylinders, valves, etc. Like kerosene, alcohol requires auxiliary heat for vaporization, although some few carbureters have been built without provision for heating the atomized product. The heat may be applied by any of the ways enumerated under kerosene. The future form of carbureter for alcohol seems problematical, but a likely type is shown in Fig. 30. This carbureter, known as the double float type, is constructed to use either gasoline or alcohol, thus permitting the

start to be made on gasoline (which will volatilize cold) and subsequent running to be done on alcohol. Suppose that compartment *b* is used for gasoline, and *a* for alcohol. *c* and *d* are floats in these chambers that regulate the level of liquid in the chambers by opening and closing the needle valves *g* and *h*. *e* and *f* are springs that can be used to keep either needle valve (*g* or *h*) closed when the

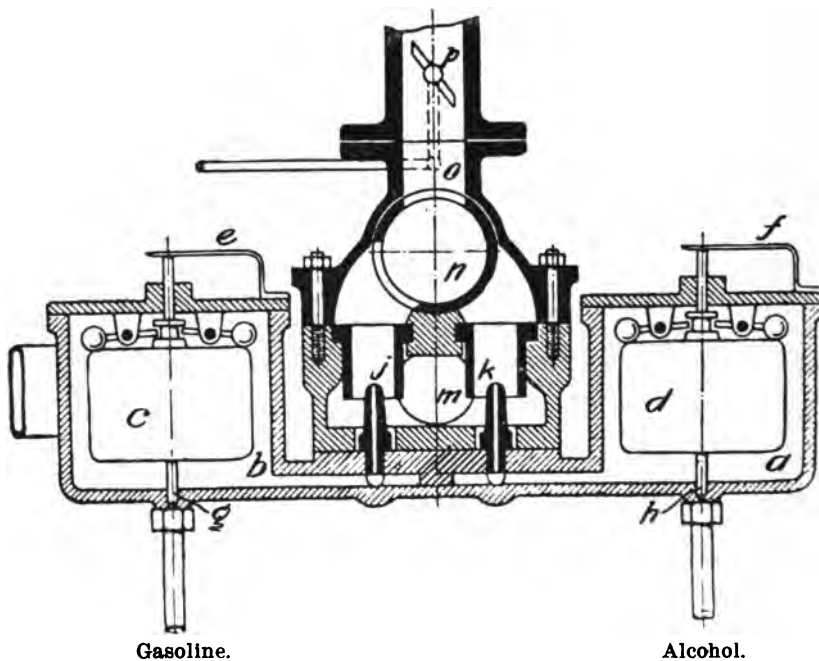

FIG. 30.—Alcohol Carbureter.

other is in use. *j* and *k* are nozzles communicating with the fuel chambers *b* and *a*. *m* is the air inlet and *n* is a valve which can be rotated so as to connect the air inlet *m* with the admission pipe *o* by way of either *j* or *k*. *o* is the admission pipe to the engine and *p* is a throttle. The carbureter is shown with both needle valves closed.

The operation is as follows: Using gasoline to start, push aside the spring *e* allowing the float *c* to operate and admit gasoline to *b*.

With the valve *n* in the position shown, the apparatus becomes a simple float valve gasoline carbureter. The air is drawn in through *m* over *j*, sucking up gasoline vapor, through *n* and out at *o*. When the engine is warm and it is desired to shift to alcohol, the spring *e* is pushed to the closed position and *f* is pushed aside, allowing the float *d* to operate. The valve *n* is turned so as to connect *m* and *o* by way of *k*. We now have a simple float valve alcohol carbureter, the air being drawn into *m* over *k*, sucking up alcohol vapor, and going out by way of *n* and *o*. This type of vaporizer is supplied with *preheated* air.

5. Oil. Heavy oils, those heavier than kerosene, are generally sprayed directly into the cylinder. Air is forced through a separate valve into the cylinder either with or ahead of the fuel. Upon coming into contact with the hot cylinder or its contained hot air the atomized oil is vaporized. One of the most difficult features of design connected with the "heavy oil" engines is to reduce the deposits of carbon that tend to form. When a heavy oil is volatilized there is a strong tendency toward chemical change. Its heavy hydrocarbon constituents tend to decompose into lighter ones. This reaction, called "cracking," which is absent when the lighter fuels are carbureted leaves a carbon residue. The Diesel engine, which is described in Chapter X, is probably the most interesting type of oil engine. As its operation is described later it is omitted here.

CHAPTER VI

IGNITION

Next to carburetion, the most important feature in internal combustion engine operation is proper ignition. The abandonment of naked flame ignition because of its uncertainty leaves three general methods of igniting the compressed mixture: (1) the electric spark; (2) by contact of the mixture with a heated tube; (3) by compressing the charge until its temperature reaches the point of ignition.

The first method, that of the electric spark, is the one in most common use, the reason being that it has reached a nearly perfect state of development and it can be more easily "timed." By timing the spark is meant regulating the point in the stroke at which ignition takes place. For high-speed engines electrical ignition is the only one flexible enough for accurate regulation. It is obvious that with an engine running at 600 revolutions per minute, the stroke being but $1/20$ second, it would be extremely difficult mechanically to vary to a nicety the point in the stroke at which ignition will take place.

Electric Spark. By shooting a hot electric spark through a compressed charge ignition will take place. Electrical ignition may be subdivided into two classes: (1) jump spark system; (2) make and break system.

1. Jump Spark. This system requires among other things a spark plug, which is shown in the circuit in Fig. 31. A current of high potential is made to jump across a gap between two terminals of the spark plug. This plug, which is screwed into the cylinder head, has its gap surrounded by the compressed mixture at the moment of ignition. Closing the circuit causes the spark to leap and this ignites the charge.

A Single Cylinder Ignition Circuit is shown in Fig. 31. The spark plug is screwed into the cylinder head *b*. The plug consists of the steel casing *a* which screws into the cylinder head *b* and thus the terminal *g* is grounded at the engine. The other terminal *h*

is insulated from the rest of the plug by the porcelain collars *c* and *d*. *f* is a gas tight washer of asbestos. These collars and washers are made in a variety of shapes and of different materials, but the principle is the same in all cases.

The system consists of two circuits, a primary and a secondary. Following the primary circuit, shown by the heavy line, it goes from the ground *J* through the battery *K* to the buzzer *L*, through the

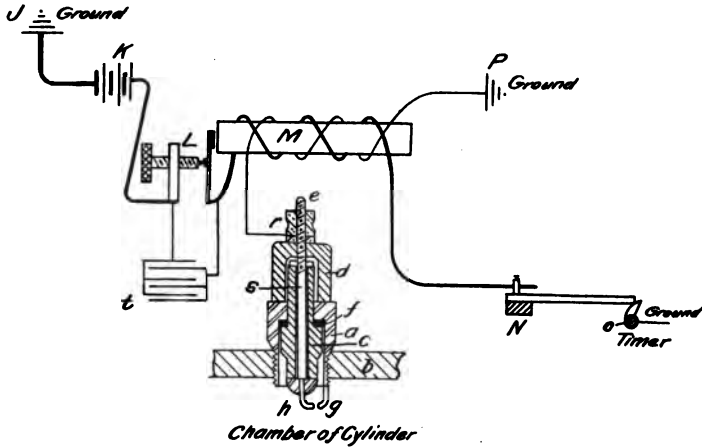

FIG. 31.—Single Cylinder Jump Spark Ignition Showing Details of Spark Plug.

primary windings of the coil *M* to the terminal *N* of the timer. The timer shaft *O* revolves, and this shaft being grounded, the circuit is completed by the cam on the shaft. The secondary circuit leads from the ground *P* through the secondary winding of the coil *M* to the terminal *r* of the spark plug then down the spindle *s* to the point *h*. The point *g* being grounded, the circuit is completed by the gap between the two points of the plug. When the primary circuit is completed by the timer, sending current through the primary windings of the coil, a high tension current is induced in the secondary windings and this current is strong enough to overcome the resistance of the gap, which it leaps. *t* is a condenser connected across the terminals of the buzzer. Its function is to damp the break spark at *L*.

Magnetos. The foregoing system uses battery current. A "high tension" magneto, which is an apparatus similar to a dynamo, may furnish the current. In this case the magneto furnishes the current direct to the plug, the battery and coil being eliminated. If a "low tension magneto" is used, the current must be stepped up by the use of a small coil or "booster." In this case the buzzer is elimi-

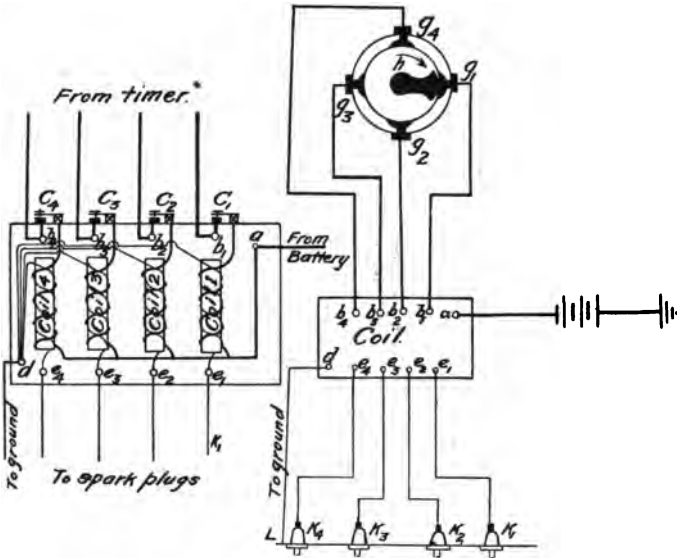

Fig. 32a.—Wiring of Coils. Fig. 32.—Wiring for Four Cylinder, Jump Spark Ignition.

nated. The function of the buzzer is to break up the spark at the gap into a vibrating series, thus increasing the certainty of ignition.

Multicylinder ignition, Fig. 32, illustrates four-cylinder engine wiring.

Fig. 32a shows the wiring of the coil. The timer shaft *h* revolves, making contact with the terminals *g*₁, *g*₂, *g*₃, *g*₄ in succession. *h* is grounded to the engine. *a*, *b*₁, *b*₂, *b*₃, *b*₄, *e*₁, *e*₂, *e*₃, *e*₄ are plugs on the outside of the coil box and are connected as shown in Fig. 32a. The plug *a* connects to the battery, *d* to the ground, *e*₁, *e*₂,

etc., to the spark plugs, and b_1, b_2 , etc., to the terminals g_1, g_2 , etc., of the timer. k_1, k_2 , etc., are the spark plugs. c_1, c_2 , etc., are the buzzers. The shaft h being in the position shown, the primary circuit goes from ground h , through g_1 to b_1 , through vibrator c_1 and primary windings of coil 1 to plug a , thence to battery and ground. The secondary circuit 1 leads from ground L to plug d , through secondary windings of coil 1, where a high tension current is induced, to plug e_1 , thence to spark plug k_1 . This circuit is similar to the one cylinder circuit described above. When shaft h is

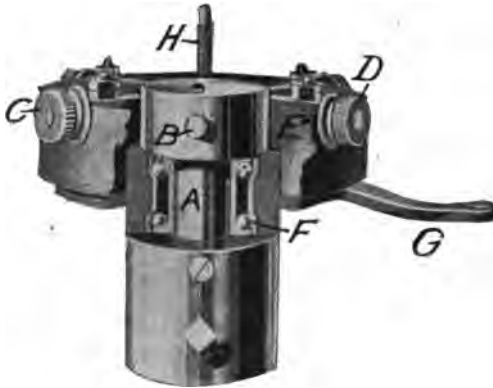

FIG. 33.—Splitdorf Timer, Wipe Contact Type.

revolved to make contact with g_2 , the current flows through coil 2 to spark plug k_2 , etc., and in this manner the cylinders are ignited in rotation.

The Timer. Means must be employed with a multicylinder engine to ignite each cylinder in turn at precisely the proper instant. This is accomplished by the timer. It is interposed in the primary circuit with a terminal for each primary wire from the coil, Fig. 32. There are two general types of timers, the wipe contact and the La Costa or roller contact type. Fig. 33 shows the construction of the Splitdorf wipe contact type. The shaft A , which is grounded, has secured to it a head which carries the spring point B .

As the shaft *A*, which is driven by gearing generally from the cam shaft, revolves, the point *B* makes contact with the terminals *C*, *D*, etc., in turn. These terminals are insulated from the collar of the timer *E*. When contact is made with any terminal, the primary circuit corresponding to that terminal is completed and the corresponding cylinder is fired. The shaft *A* runs on ball bearings *F*. The collar *E*, which carries the several terminals, can be shifted by the lever *G* to advance or retard the spark. The spindle *H* holds



FIG. 34.—Splitdorf Timer, La Costa Type.

the cover on the timer. This is a similar type to the timer on the two cylinder engine in the laboratory.

Fig. 34 illustrates the La Costa type of timer. The shaft *A*, which is revolved by gearing from the cam shaft, is grounded, and carries the roller contact *F*. The terminals *B*, *C*, *D* and *E*, are insulated from the rest of the timer. The primaries for each cylinder lead from the coil to these terminals. As the roller *F* makes contact with the plates *G* of each terminal it completes the primary circuit of the cylinder corresponding, firing each cylinder in turn. The spark can be advanced or retarded by rotating the collar carrying the terminals by means of a lever attached to *H*.

2. Make-and-Break System. This system, which is a mechanico-electrical one requiring cam or other gearing to make and break a contact inside the cylinder, is applicable to slow speed engines, and for this special duty has some advantages over the jump spark. A moving contact in the electrical circuit is mechanically made and broken inside the cylinder. At the *break* a spark will leap between

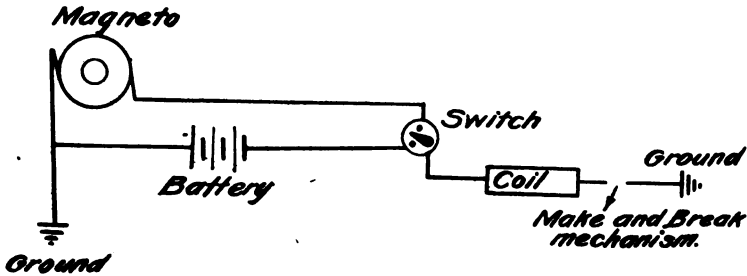

FIG. 35.—Circuit for Make and Break Ignition.

the contacts igniting the mixture. This system admits of two methods: (1) the wipe spark; (2) the hammer break. By the first method the contacts are made to brush together and by the second the contacts are brought together sharply and separated. The wiring for both methods, shown in Fig. 35, is similar. A small coil is employed to step up the current, but no vibrator is used as this would cause a spark to occur at make as well as break, thus probably igniting the charge prematurely. The circuit shown admits of battery or magneto current.

The **wipe spark** mechanism is shown in Fig. 36. The rod *b* oscillates the collar *a* by means of the cam *c* on the countershaft. The collar *a* carries the contact point *d*, grounded to the engine. As the collar *a* oscillates the point *d* wipes past the spring point *e*

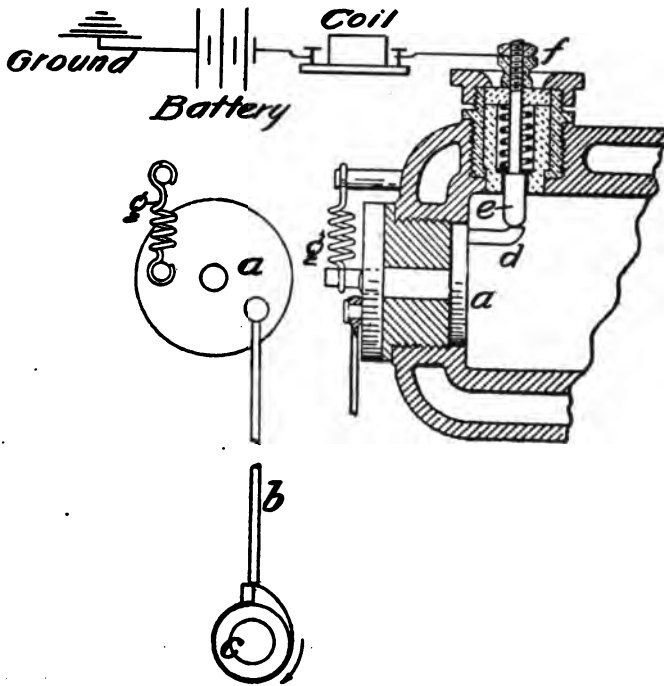

FIG. 36.—Wipe Spark Igniter.

completing the circuit. The spring *g* quickly returns the collar to its original position when the cam releases the rod, and the circuit thus being broken a spark will occur between the points *d* and *e*. The source of current is connected to *e* by the terminal *f*. Terminal *f* and point *e* are insulated from the rest of the mechanism. The advantage of the wipe spark over the hammer break lies in the fact that the sliding contact prevents carbon deposits on the points.

Hammer Break. The principle of the hammer break is shown in Fig. 37. The spindle *a*, carrying the contact *b*, is actuated by cam and rod through the lever *c*. *d* is a spring to keep *b* against the collar. *f* is the cylinder head. Contact *b* is grounded to the cylinder. Contact *e* is insulated from the cylinder and its terminal *g* is connected to the source of current. When the contacts *e* and *b* are separated mechanically, a spark occurs. The cam actuating this gear is generally situated on the countershaft of the engine.

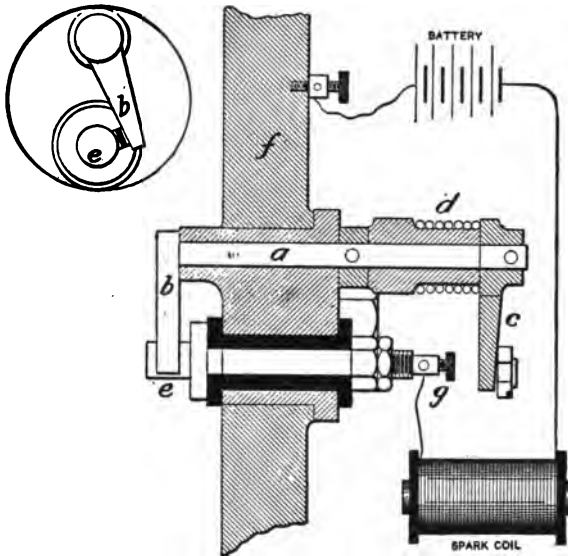

FIG. 37.—Hammer Break.

Advantages and Disadvantages of the Different Electrical Systems

The make-and-break system is the simpler electrically and less trouble occurs from insulation and short circuits because a low tension current is used throughout. It is mechanically more complex, hence is more suitable for low-speed engines, and hard to adapt to high-speed engines.

Although electrically more complex than the make-and-break system, the jump spark system has no moving parts inside the cylinder, and its flexibility as regards spark adjustment makes it the universal system for high-speed engines.

General. All contact points and the points of a spark plug are made of a platinum alloy or other heat resisting conductor. The points must be kept clean and free from carbon, as this formation tends to form short circuits across the gap, thus damping the spark. All connections should be so arranged that they cannot jar loose and the insulation must be protected from heat, oil, and especially water.

Dual Ignition. By a "dual ignition" system is meant one in which the current is supplied from either a battery or magneto, or from both, at will. Some systems have a separate set of spark plugs for each source of current supply and in this case the system is in effect two separate systems. The dual ignition system proper, in which current may be obtained through one set of plugs from either battery or magneto, is shown in Fig. 38.

F is a four way switch which operates as follows: Connecting *a* and *b*, the current goes from the dynamo to the primary of the coil direct where it is converted to a high tension current. Connecting *a* and *d* the current goes from the battery direct to the primary of the coil. Connecting *c* and *d* the voltage of the battery can be read by a volt-ammeter in the circuit. The secondary circuit *s* is similar to that shown in Figs. 32 and 32a.

This should not be confused with double ignition, in which there are two separate circuits and sets of spark plugs, one for the battery and one for the magneto.

There is a tendency in modern practice to have two spark plugs for each cylinder, so as to ignite the charge at two points simultaneously. This is theoretically excellent as it will accelerate flame

propagation, but there are several difficulties that are hard to overcome. First, the two sparks must occur at correctly timed instants, otherwise the object of the system would be defeated. Second, if the two spark plugs are situated close together little benefit is derived. The first difficulty has been overcome by several manufacturers of ignition specialties, and where design permitted the installation of two spark plugs widely separated, the author has heard of some remarkable results.

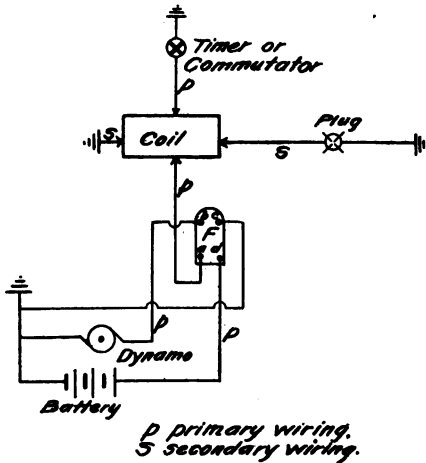

FIG. 38.—Dual Ignition Circuit.

Master Vibrator. A variety of spark coil recently placed on the market is fitted with what is called a master vibrator. In this coil there is one common buzzer for the coils of all cylinders. The system shown in Fig. 32a could be modified as follows: cut out all the buzzers shown and lead the primary directly from the timer to the coil. Insert a buzzer (master vibrator) in the common primary line from the plug *a*. The advantage of this system lies in the fact that the vibrators give more trouble than any other part of the ignition system, for an arc is constantly present that burns and fouls the vibrator contacts, and obviously one vibrator is easier to keep clean and adjusted than are four.

Hot Tube Ignition. Although rapidly being superseded by the electrical systems, the hot tube is still being furnished by some manufacturers. A typical hot tube igniter is shown in Fig. 39. One end of a small tube communicates with the cylinder, the other end is closed. A Bunsen burner, located in a surrounding chimney, keeps part of the tube at a red heat. The chimney is partially lined with asbestos or other non-conductor, which reduces loss of heat by radiation.

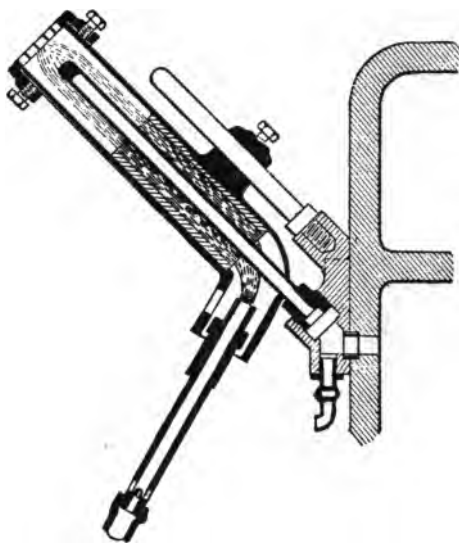

FIG. 39.—Hot Tube Igniter

On the exhaust stroke the tube is filled with exhaust gases. On the suction stroke part of these gases remain in the tube. On the compression stroke the exhaust gases are compressed into the closed end of the tube and some fresh mixture is compressed into the cylinder end of the tube. When the fresh charge reaches the hot part of the tube it ignites, and near the dead center, when the velocity of flame propagation exceeds the velocity of the entering mixture, explosion takes place. The point of ignition may be varied by shifting the chimney carrying the Bunsen burner along the tube by use of the set screw shown. Accurate timing for slow-speed

engines is obtained by inserting a valve at the cylinder end of the tube. By opening this valve at the correct point in the stroke the fresh mixture comes in contact with the hot tube. The valve is actuated by cam gear from the countershaft.

Ignition by Compression. When a gas is compressed its temperature rises and it is possible to compress the mixture to the point of ignition. There are two distinct methods of applying this principle.

a. By the Diesel method air is compressed in the cylinder until its temperature is far above the ignition point of the fuel and the fuel is injected into this heated air during the working stroke.

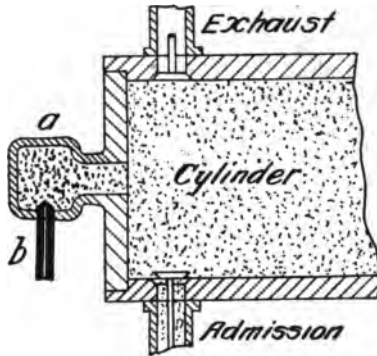

FIG. 40.—Ignition by Compression.

b. The second method, sometimes known as the hot bulb method, is shown in Fig. 40. A bulb *a* on the cylinder head is maintained at ignition temperature by the heat of compression. This bulb is generally encased (not shown in figure) to reduce loss of heat by radiation. To start the engine the bulb must be heated by an outside flame. When gas is the fuel, the tube *b* is omitted and the action is similar to the hot tube. The compression is so regulated that on the compression stroke the velocity of flame propagation will exceed the velocity of gases entering the neck of the bulb at the proper point in the stroke for ignition. For oil fuel the tube *b* is used, air entering the admission valve and oil fuel at *b*. The hot tube acts as a vaporizer. Timing the point of ignition is accomplished by regulating the compression pressure.

CHAPTER VII

COOLING AND LUBRICATION

Cooling the Gases. One of the measures of efficiency for an internal combustion engine is the effective utilization of the available heat energy. This in turn depends upon the initial and final temperatures of the gases that develop the pressure, if these gases be cooled as far as possible by transforming their heat into work. Experiments have been made along the line of injecting water into the cylinder both before and after ignition of the charge, on the theory that the heat absorbed from the ignited mixture would vaporize the water and reappear as work on the piston in the form of pressure due to adiabatic expansion of the water vapor. Although this reduces the loss of heat in the exhaust, it is open to the objection that it reduces the net effective pressure. It is not in common use.

Cooling the Cylinder. Due to the high heat developed by the combustion of the mixture it becomes necessary to cool the metal of the cylinder walls, pistons, valves, etc. Were this temperature not reduced the result would be leaky valves, deformations, defective alignment, seizing of piston, and oxidation of metal. There are two methods of cooling the cylinder: (1) water cooling; (2) air cooling.

Water Cooling. The cylinder is jacketed and water is circulated through the jacket. Where unlimited water is available the exhaust is lead to a drain. If the water supply is limited a tank is employed. Fig. 41 illustrates the use of a tank and the thermo-syphon system. The circulating water enters at the bottom of the jacket and, as it becomes heated, rises, flowing out at the top to the tank. A continuous circulation is thus established. When this system does not furnish a circulation that is rapid enough, a pump is placed in the supply pipe *a*. For slow speed engines this pump may be of the plunger type, if the water is free from foreign particles such as dirt and marine growth, or of the centrifugal type if the water is not clear as in marine practice. The pump is designed

for the probable working speed because one that would supply sufficient water at a designed high working speed would be deficient at low speed, and one that was designed for a low speed might cool the cylinder to too low a point for efficiency at high speed.

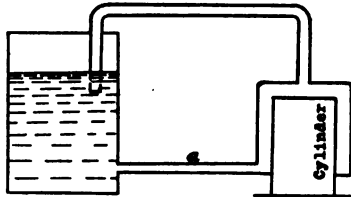

FIG. 41.—Thermo-Syphon System.

Fig. 42 shows the system used for cooling automobile and aeroplane engines, where only a small amount of water can be carried. The radiator shown consists of a top and bottom header connected by vertical tubes. These tubes are covered with thin fins to increase

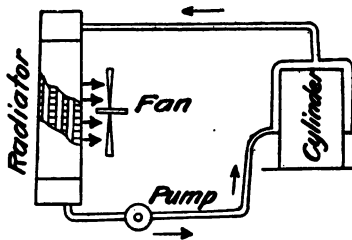

FIG. 42.—Water Cooling, Radiator and Pump.

their radiating surface. The water enters the cylinder jacket at the bottom, flows out at the top, heated, and returns to the radiator where it is cooled by passing through the tubes. The circulation is aided by a pump, and a fan circulates the air through the radiator between the tubes. By reusing the circulating water it is "broken," that is the salts are precipitated, hence there will result less sediment in the jackets.

Cooling valves, pistons, etc. In all large size engines the heat from the piston will not radiate to the cylinder walls rapidly enough to maintain a safe piston temperature. This necessitates that pro-

vision be made to water cool the piston. Water is introduced to hollows cast in the piston, either by flexible connections or by two hollow tubes that slide through a stuffing box and enter chambers, one of which contains cool water under pressure and the other of which receives the heated discharge water.

Admission valves are kept cool by the cool entering mixture, and where practical to let this cool mixture impinge on the exhaust valve it aids in maintaining the latter at a safe temperature. The cylinder jackets are carried as near as possible to the valve seats. Exhaust valves for large engines are generally cast hollow and are water cooled, the circulating water entering the valve through a flexible tube.

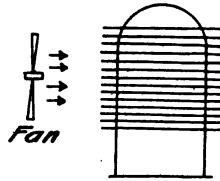

FIG. 43.—Air Cooled Cylinder.

Air Cooling. This system is not used as extensively as water cooling. A few automobile and aeroplane engines and all motorcycle engines are air cooled. The cylinder is cast with a number of fins or webs on its outside surface to increase the radiating surface. A fan is installed to increase the air circulation as shown in Fig. 43. Fuel economy at moderate horse-power and speeds is higher than in the water cooled system, due to the higher cylinder temperatures, but as the engine becomes heated the horse-power developed falls below that which should be developed for given cylinder dimensions. As the cylinder dimensions increase it becomes more difficult to carry off the heat fast enough and there is a practical limit to the size engine that can be air cooled.

Lubrication

The external lubrication of an internal combustion engine presents no novel features and requires no comment, but the internal lubrication of the cylinder, piston, etc., is vital to the safety of the

engine. A steam cylinder lubricates itself by condensation of steam on the cylinder walls, but due to the intense heat in the cylinder of an internal combustion engine, and due to the high piston speed it is necessary to have a film of oil between the piston and the cylinder walls at all times.

Kind of Oil. The intense heat of the cylinder will tend to evaporate the oil and cause gumming, therefore an oil of high heat test must be used. As this is limited to 600°, evaporation of the lubricant cannot be eliminated entirely; therefore a thin oil that will not gum upon partial evaporation is necessary. Animal and vegetable oils will decompose under high heat and cause oxidation and a carbon deposit upon the cylinder, not to mention the possible liberation of destructive acid. As a partial combustion of the cylinder lubricant is always liable to take place, oil must be used that does not leave any solid residue. Only special grades of mineral oils can be used. These are designated commercially as "gas engine cylinder oils" and come in various grades to suit the varying conditions of speed, load, etc. Oil should be tested carefully for the presence of acid. A good body and low internal friction are very desirable.

Two distinct methods of piston and cylinder wall lubrication are employed: (1) splash system; (2) mechanical feed. The splash system is the simpler as it does not require a pump for distributing the oil. The crank case is closed and oil is maintained in the case at such a height that the crank or a small lug on the crank will dip into the oil at each revolution, throwing the oil up on to the cylinder walls. The piston spreads the oil over the cylinder wall evenly on the up stroke. By this system the oil supplied to the cylinder walls is approximately proportional to the speed of the engine. At the same time oil is splashed on to all of the bearings, or a small pump may draw oil from the case and distribute it to all of the bearings, returning it to the case. This system is used only for engines of medium and low horse-power.

Lubricators. The mechanical feed appears in various forms. One is shown in Figs. 44 and 45. The oil is fed by pump or mechanical lubricator into the oil duct to the oil ring around the base of the cylinder, Fig. 44. At each stroke the lower edge of the

piston dips into the oil in the oil ring and oil is drawn up the cylinder wall. The lubricator is shown in Fig. 45. A small belt from the main or countershaft drives the pulley *a*. This revolves the spindle and crank *b, b*, which carries the loose wire *c*. This

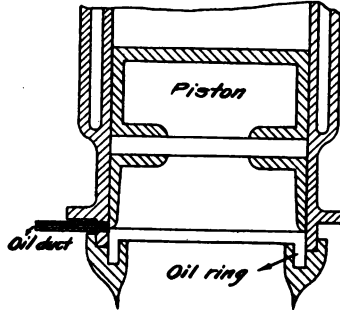

FIG. 44.—Oil Ring.

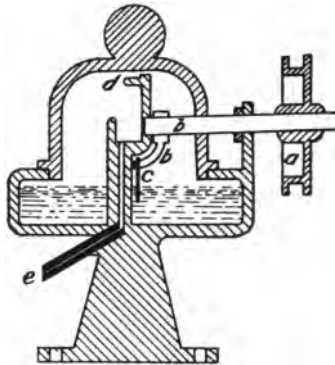

FIG. 45.—Mechanical Lubricator.

wire dips into the oil at each revolution and carries a small amount to the wiper *d*, from which the oil drips to the passage *e*. This passage connects with the oil duct in Fig. 44. As the pulley *a* revolves at a certain relative speed to the main shaft, the oil supplied is proportional to the speed. In Fig. 45 the central bracket which carries the wiper *d* is back clear of the path of spindle and crank *b, b*, as they revolve.

CHAPTER VIII

GOVERNING AND INDICATOR CARDS

Governing

Internal combustion engine governing is a more complex proposition than steam engine governing. In the latter case the medium of power, steam, is stable, and for a constant pressure a given governor position will always give the same cycle, hence constant power. On the other hand the working fluid in an internal combustion engine is far from stable. This medium consists of the gas resulting from the chemical reaction when fuel and air are mixed and ignited in the engine cylinder. Thus it is apparent that for a given fuel the stability of the internal combustion engine medium depends upon the accuracy and variability of mixture, degree of stratification of the charge, and variations in ignition. The perfection of agents to keep these variants within reasonable limits has made possible the application to internal combustion engines of governors which confine the speed fluctuations to small limits.

As in the steam engine, the governor must fulfill two essentials, viz.: It must automatically control the speed as far as possible, and it must be isochronal in the sense that under varying loads it will make the engine perform its cycles in equal times.

The mechanical form of the governor varies as in the steam engine, being of such forms as the fly-ball, inertia, and vibrating types, etc. The systems employed are:

1. The hit and miss system.
2. Throttling the mixture.
3. Varying the quality of the mixture.
4. Varying the point of ignition.
5. Throttling the exhaust.
6. Combination systems.

Governing by the Hit and Miss System. In one of its forms this was the earliest system employed extensively to regulate internal combustion engine speed. It effects this regulation by omitting an

explosion when the speed exceeds that desired. When running at the required speed the cycles follow each other at equal intervals; if anything disturbs this equilibrium so as to increase the speed the governor acts and prevents an explosion (causes a "miss") on the following cycle. This miss reduces the speed and the governor acts in the opposite direction, causing the explosions to recur. The greater the excess speed, the greater will be the proportion of "misses" to "hits" until equilibrium is again restored. There are three varieties to this system:

1. Keeping the fuel valve closed so that only air is drawn into the cylinder during the miss cycle.
2. Keeping the inlet valve closed, thus preventing admission of both air and fuel.
3. Keeping the exhaust valve open, thus destroying suction action on the admission stroke of the cycle.

The mechanical operation of the first two methods is the same, the only difference being that in the first case the governor acts upon the fuel valve and in the second case it acts upon the admission valve. Fig. 46, called the pick-blade governor, illustrates this method. *A* is the fuel or admission valve. *B* is a bell crank lever which actuates the valve, opening and shutting it during the regular cycle. This bell crank lever is in turn actuated by the cam *C* on the countershaft. The pick-blade *D* acts as the push rod between the valve stem and the lever *B* during a regular cycle. This pick-blade is connected by rod *E* and bell crank *F* to a collar *G* on the governor *H*. The governor is run by the main or countershaft so that its speed is proportional to that of the engine. When the pick-blade engages the valve stem it is in position for running at the desired speed. If this speed is exceeded, the governor balls fly outward, raising the collar *G*. This causes the pick-blade to move to the right as shown and disengage the valve stem entirely. During the next cycle and until the speed is reduced to the normal, the pick-blade does not engage the valve stem and the valve does not lift. This operation causes misses. When the speed is reduced the required amount, the balls of the governor assume their original position, the pick-blade again engages the valve stem, and the original conditions are resumed.

The system of governing by keeping the exhaust valve open is often applied to engines that have an automatic spring loaded admission valve. By applying the governor to the exhaust valve this can be kept open when the speed exceeds that desired, and with this

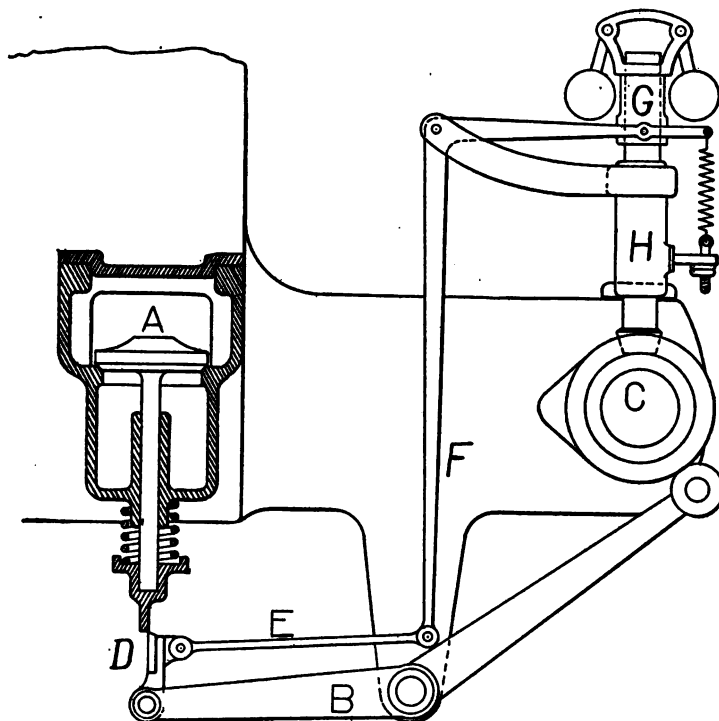

FIG. 46.—Pick-Blade Governor. Governing by the "Hit and Miss" System.

open no vacuum is created on the suction stroke and hence no fresh charge is drawn in. The result is a miss on the following cycle. When normal speed is again reached, the exhaust valve is released and functions as originally.

It is obvious that this system is open to many objections. In a four cycle engine the omission of a working cycle will cause an appreciable variation of the speed even with a large fly-wheel, and if

the load is suddenly increased just after the miss cycle, this reduction becomes objectionably large. After the idle cycle, the first impulse is stronger than normal due to the cylinder being well scavenged during the miss cycle. An engine employing the hit and miss system requires a very heavy fly-wheel to produce a reasonably uniform angular velocity in the crank shaft. This system is unsuitable for work requiring close regulation of speed, such as electric lighting, etc. Its advantages as a system are its mechanical simplicity, and its ability to run on the economical quality of mixture without variation.

Governing by Throttling the Mixture. A more efficient system of governing than the foregoing is that of throttling the normal mixture so that a smaller quantity of the charge is drawn into the cylinder, but the *proportions* of that charge are unchanged. The governor operates the main throttle which is generally placed in the admission line between the carbureter and the engine. The advantages of this system are that the engine can work on a constant mixture and receives an impulse every cycle. The pressure in the cylinder is reduced by throttling, due to both reduced fuel supply, and to consequent decreased compression. By keeping a constant quality the danger of ignition failure is reduced.

When this system is used the engine is designed for a very high compression at full power so that with a reduced amount of fuel the remaining compression will enable a good thermal efficiency to be attained. The advantages of this system has caused a tendency for its general adoption for many uses.

Governing by Varying the Quality of the Mixture. For a given quantity of mixture the initial pressure obtained will vary with the proportion of fuel and air in the mixture. This is the principle of variable quality governing. The governor may act upon the fuel valve, varying the amount of fuel per cycle while the amount of air remains constant, or may act upon the air valve, varying the amount of air per cycle, the fuel valve being automatic. The result in either case is to impoverish the mixture when the speed exceeds that for which the governor is set. It has the advantage that, although the total charge of fuel and air may vary in quality, the *quantity*

admitted each cycle is constant, therefore the compression is the same for varying loads. Theoretically the result should be equal thermal efficiencies for all loads, but practically the fuel consumption rapidly increases as the load decreases.

The reason for this decrease of thermal efficiency with the load under this system of governing is that as the mixture becomes rarer, ignition becomes more difficult and combustion much slower, resulting in greater heat losses to the cylinder walls. If carried too far the mixture may become so rare that it cannot be ignited.

Governing by Varying the Point of Ignition. The ignition systems of nearly all internal combustion engines are so fitted that the point in the engine stroke at which ignition takes place may be varied. The electrical systems particularly lend themselves to this form of regulation. Thus the charge may be ignited before the piston reaches the end of the compression stroke ("advanced spark"), at the end of the compression stroke when the compression is a maximum, or on the expansion stroke beyond the dead center ("retarded spark"). It is evident that the maximum impulse is obtained if combustion takes place when the compression pressure is a maximum. If ignition takes place after the piston has passed the dead center and started on the combustion stroke, then the compression being less than maximum, the power obtained is less than full power. If the charge is ignited and combustion takes place before the piston has passed the compression stroke dead center, it is evident that the piston will be driven backwards ("back fire") unless the fly-wheel inertia is sufficient to carry the piston over the dead center.

This system is used extensively in marine engines as well as in motor vehicles. Its use facilitates hand starting by preventing "back firing." To start, the ignition is retarded well past the dead center. After the engine is running the spark is advanced until ignition takes place a little ahead of the dead center. The reason for this is that, combustion not being instantaneous, if the charge is ignited at the proper point before the piston reaches the dead center, the maximum pressure of combustion will occur at the end of the stroke, and the expansion will thus be a maximum.

The proper ignition point is found as follows: Advance the

spark until a distinct "knock" is heard. Then retard the spark until this knock just disappears.

Governing by Throttling the Exhaust. If the exhaust be throttled it will produce a braking effect or back pressure during the exhaust stroke. This effect is particularly noticeable in a single cylinder engine. Another effect of throttling the exhaust is to leave some of the products of combustion in the cylinder which prevents a full charge being drawn in on the suction stroke. Moreover, the reduced charge is diluted by the exhaust gases present. This system being highly inefficient is little used.

Combination Systems of Governing. Although not general, combination systems are sometimes used. Some American Crossley engines govern by the variable quantity or quality method at high loads and by the hit and miss system at low loads. Some engines govern by the variable quantity method at high loads and by the variable quality method at low loads, and *vice versa*. A thermally correct method is that advanced by Letombe. This consists of increasing the time of opening of the inlet valve, but decreasing the lift of the fuel valve as the load decreases. In a sense this is quantity regulation, but the increased opening of the inlet valve increases the total charge, and thus the leaner mixtures are more highly compressed than the richer mixtures that are used at the higher loads. Attempts have been made to vary the compression space so that the compression can be made constant for all loads, but no practical method embodying this principle has been devised.

Indicator Cards

The theoretical four cycle engine indicator card with variations is shown in Figs. 47 to 52. Fig. 47 illustrates a theoretically perfect card. All the strokes and events in the cycle are marked and starting at any point the cycle can be easily traced. It is apparent when tracing the cycle that the lower loop is traced in the opposite direction to the upper loop. This indicates a loss of work and the work represented by the lower loop must be subtracted from that represented by the upper loop to get the net work of the cycle. In

cards 48 to 50 the suction and exhaust strokes are omitted for simplicity of discussion.

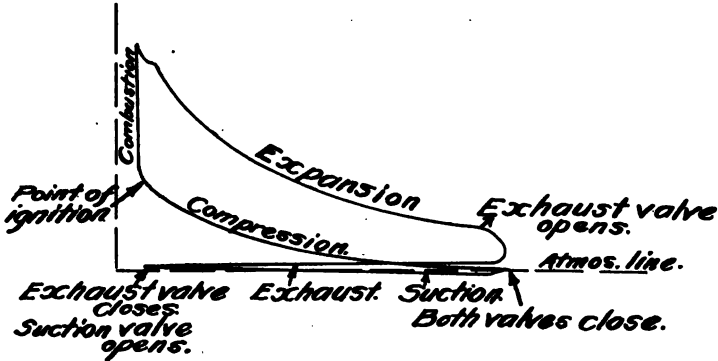

FIG. 47.—Normal Indicator Card.

Fig. 48 shows the effect of throttling the normal charge. A number of cards are superposed to illustrate the point that as the charge is throttled the card becomes smaller, showing a decrease in total

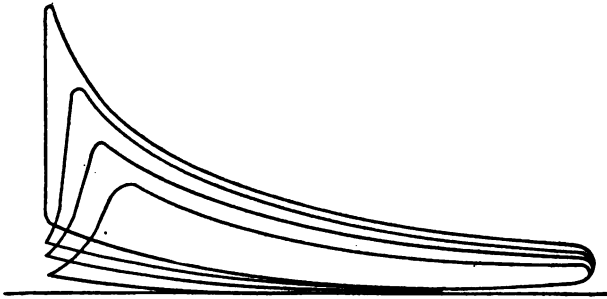

FIG. 48.—Effect of Throttling the Normal Charge.

work. Throttling decreases the amount of mixture that is drawn in each cycle. As the charge is reduced, the compression space being the same, the compression pressure is lowered, and as a direct result of the reduced pressure combustion is slower. These points are indicated in the card by the lowered compression line and the sloping combustion line respectively.

Several cards are superposed in Fig. 49 to show the effect of retarding the ignition. If ignition takes place after the piston passes the dead center this is indicated on the card by the combustion line returning along the compression line until the point of ignition is

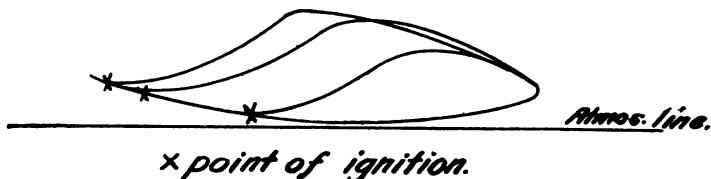

FIG. 49.—Effect of Retarding the Ignition.

reached. The later the ignition, the lower will be the compression at the point of ignition, therefore the combustion will be slower and the combustion line will be lower.

Fig. 50 is a card from an engine that has the spark advanced too far, in other words the ignition is too early. Ignition in this case takes place before the end of the compression stroke, the maximum

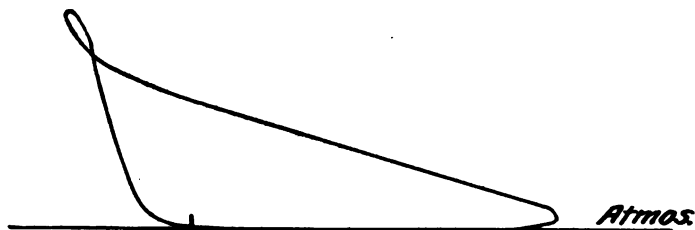

FIG. 50.—Ignition too Early.

pressure is attained before this stroke is completed, and the result is a loop in the upper part of the card, which loop being traced in the reverse direction to the general direction of the cycle represents a loss of work.

Fig. 51 is a card taken from an engine with a faulty exhaust. This fault may arise from a clogged exhaust, the exhaust valve or passages may be designed too small, the exhaust valve may be incorrectly timed, the exhaust passage may be so long as to create a

back pressure or may have sharp bends or turns in it. In any case any cause that would interrupt the exhaust enough to create a back pressure will be indicated on the card by a rise in the exhaust line.

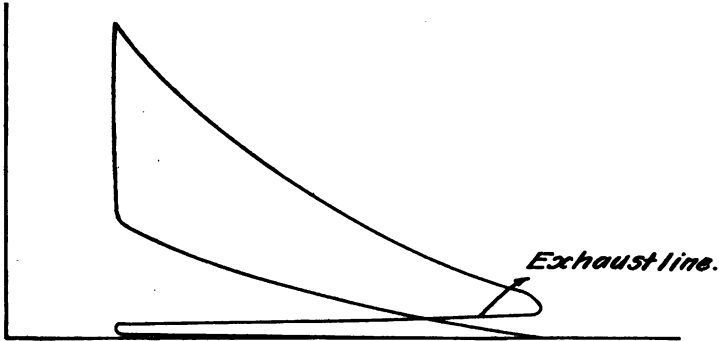

FIG. 51.—Faulty Exhaust.

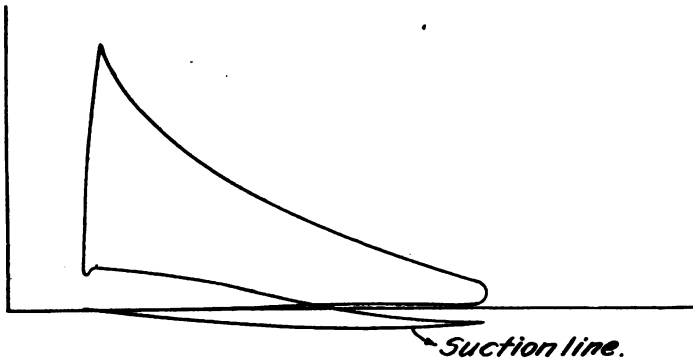
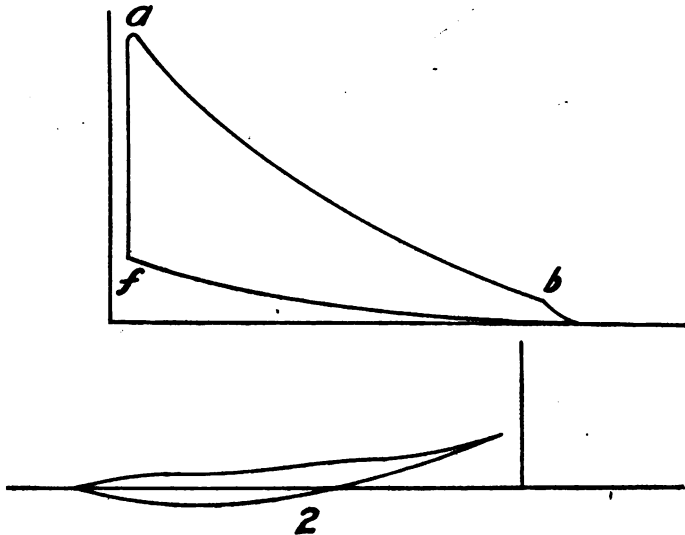

FIG. 52.—Faulty Admission or Suction.

When the suction line falls below the atmospheric as in Fig. 52, this indicates that the admission is partly choked. This may be caused by too small an admission valve, admission passages too small or too many bends in the passage, inlet choked, or not enough lift to admission valve; if a spring loaded admission valve then the spring may be too strong, thus decreasing the lift.

Fig. 53 is an indicator card from a two cycle engine, the upper card being taken from the cylinder of the engine and the lower card from the crank case or compressor. These are traced in opposite directions so that the work indicated is the difference between the works represented by the two cards. The upper card is traced in the forward direction.

From the foregoing examples it can be readily seen how important is the information that can be gained from good indicator cards.



f Ignition, a Expansion, b Exhaust, 2 Crank Case Card.

FIG. 53.—Two Cycle Engine Card.

All faults of internal working may be obtained from well taken cards. They give data on performance, and valve settings, etc., can be checked by them. Manufacturers, however, are more interested in the brake horse-power than in the indicated horse-power and all factory tests are made for the former.

Indicators. The Manograph. The power of an internal combustion engine is measured in a manner similar to that employed in measuring the power of a steam engine. That is, indicator cards are taken to obtain the mean effective pressure acting, and this, with the number of revolutions and the engine dimensions, gives the neces-

sary data for use in the horse-power formula. For slow moving, heavy duty engines, indicators, similar to steam engine indicators, may be used. These indicators have external springs. However, they are impractical for the high-speed engines because of the inertia of the parts, the liability of the cords and other flexible parts to stretch, and the frequency with which the springs break. Indicator cards for high-speed engines are taken by an ingenious device called the manograph. This indicator overcomes the inherent difficulties of the ordinary piston type of indicator by substituting a beam of light for the pencil of the ordinary indicator and this beam traces a card on a ground glass screen or a photographic

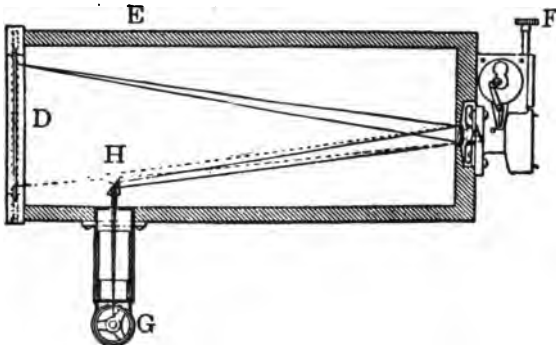

FIG. 54.—The Manograph, Cross Section.

plate. The former is used for a casual inspection of the engine's performance and the latter is used when a permanent record is desired.

The manograph, which can be seen in the laboratory, consists of a light-tight box mounted on a tripod. At one end of this box, Figs. 54 and 55, a mirror *N* is so mounted that it is capable of rotation about two axes at right angles to each other. An acetylene burner *G* on one side of the box, shining through a diaphragm, reflects a beam of light through the prism *H* to the mirror *N*. This beam is again reflected from the mirror *N* on to the screen or plate *D*. The mirror *N* is given two motions; one in proportion to the piston motion, and the other at right angles to the first in proportion to the pressure on the piston at any simultaneous piston position. As the mirror moves in two directions the beam of light will follow

a path which is compounded from two rectangular co-ordinates, one proportional to the piston position, and the other proportional to the simultaneous piston pressure. In other words the beam will trace a card on the screen similar to a card obtained by an ordinary indicator, but, since the moving part in the manograph is the beam of light which has no inertia, the inaccuracies, due to inertia of parts, etc., are eliminated.

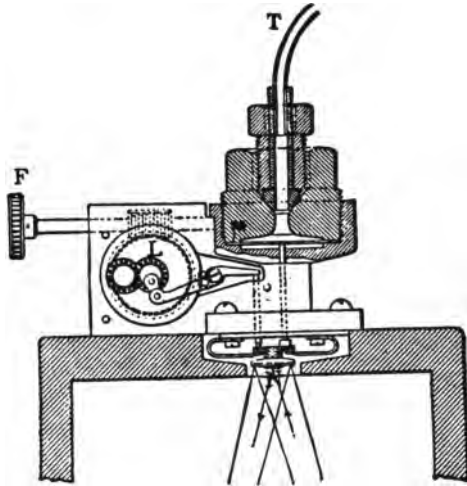

FIG. 55.—Details of Manograph.

Motion proportional to pressure is given the oscillating mirror as follows: The mirror is mounted on springs, Fig. 55, which tend to keep it parallel to the screen. The tube *T* communicates with the engine cylinder and allows the cylinder pressure to act on the diaphragm *M*. This diaphragm is connected with the mirror *N* by a pin offset from the mirror center. It is obvious that the mirror will be rotated by this pin an amount proportional to the pressure on the diaphragm, which is the cylinder pressure. The tube *T* can communicate with the different cylinders on a multicylinder engine by means of a multiway cock.

Motion proportional to the piston travel is given the mirror *N* as follows: the flexible shaft *R* (Fig. 56) is connected to the crank shaft center and rotates with the shaft. By means of the gear *L*

and a pin, which is 90° on the mirror from the other pin, motion proportional to the piston travel is imparted to the mirror, for the mirror receives one complete oscillation each revolution of the engine.

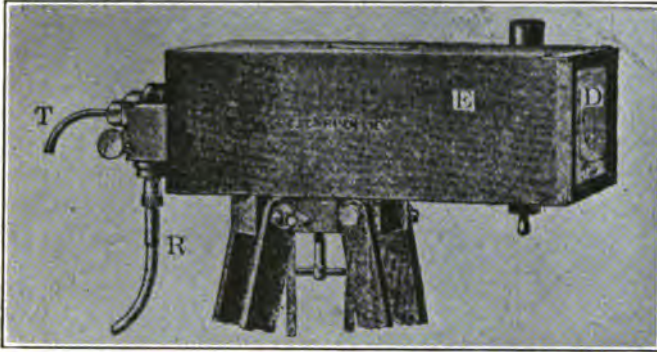

FIG. 56.—The Manograph.

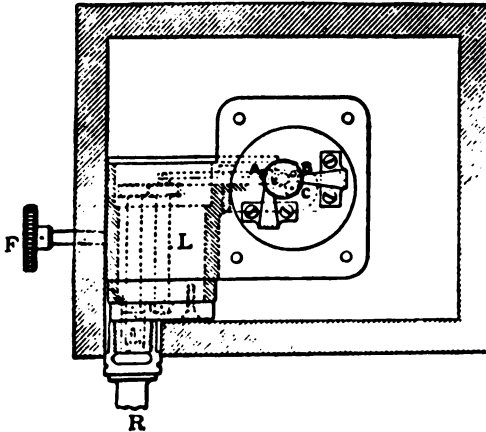

FIG. 57.—The Manograph.

The angular motion of the mirror is very small. The thumb screw *F* is for the purpose of establishing synchronism between the engine crank and the small manograph crank that actuates the pin *c*.

A manograph is installed in the laboratory on the Mietz and Weiss engine.

CHAPTER IX
**EFFICIENCY, MANAGEMENT, OPERATION, DEFECTS
 AND REMEDIES**

Efficiency

The efficiency of an engine is the ratio of the heat converted into mechanical work to the total heat which enters the engine. The efficiency of a perfect heat engine therefore depends upon two things only, viz.: the initial and final temperature of the medium, or the temperatures of source and refrigerator. The greater this range of temperature, the greater will be this efficiency. The equation for the efficiency of a perfect heat engine is $E = \frac{t_1 - t_2}{t_1}$, where E is the efficiency, t_1 the initial temperature and t_2 the final temperature.

Although illogical to employ this formula, which is applicable to the perfect heat engine only, to compare the steam and internal combustion engines, the information obtained is interesting; for example a steam engine working between 250 pounds absolute and 24 inch vacuum or 3 pounds absolute, and an internal combustion engine working between 2000° F. and 600° F. are taken. In the case of the steam engine $t_1 = 478^\circ$ absolute, and $t_2 = 334^\circ$ absolute, and $E = .30$ or 30 per cent. In the case of the internal combustion engine $t_1 = 1366^\circ$ absolute, and $t_2 = 589^\circ$ absolute, and $E = .57$ or 57 per cent. This shows that theoretically the internal combustion engine can attain about twice the thermal efficiency of the steam engine due to the increased range of working temperatures.

It can be shown that the theoretical efficiency depends upon the degree of compression only, and is independent of the maximum temperature if expansion is carried to the atmospheric pressure.

Thus $E = 1 - \frac{t}{t_c}$ where t is the temperature before compression and t_c is the temperature after compression. E therefore depends upon the ratio $\frac{t}{t_c}$. But $\frac{t}{t_c} = \left(\frac{p_c}{p}\right)^{\frac{\lambda-1}{\lambda}}$ where p is the pressure before

compression and p_c is the pressure after compression and λ is the ratio of the specific heat at constant volume to the specific heat at constant pressure. Now the value of $\frac{p_c}{p}$ and therefore of $\left(\frac{p_c}{p}\right)^{\frac{\lambda-1}{\lambda}}$ depends upon the compression *only*, therefore E also depends upon the compression only.

Although apparently paradoxical, this is an important point. If an engine receives all of its heat at one pressure and rejects all of its waste heat at another, and the reduction in pressure is utilized to do work by expansion, the efficiency is constant regardless of the maximum temperature. The *proportion* of heat converted into work is not changed by increasing the temperature before compression.

If expansion is not carried to the atmospheric pressure, and this is rare in practice, the above is not strictly true; compression is still the governing factor, but heating before compression slightly increases the theoretical efficiency.

When the *practical* efficiency is considered heating before compression decreases the efficiency by increasing the loss of heat by radiation. Ordinarily the most efficient temperature for the entering mixture seems to be between 80° F. and 85° F. Cooling water is generally carried near the boiling point, say about 180° F. This is sufficiently low to prevent deformation of the cylinders.

To Start and Stop a Motor. Small motors may be started by hand by giving a few turns to the fly-wheel or to a crank fitted to the crank shaft, but the larger engines require an auxiliary starting mechanism. Some engines, such as the Standard, are fitted so that they may be run by compressed air for a few revolutions until the first explosion is obtained. Another method is to introduce a charge of mixture into a cylinder by a pump, and then to fire this charge by the igniter or a detonator. When using this latter method, care must be taken that the piston is on the expansion stroke, for, if it is on the compression stroke, a back-fire will result and the engine will start in the reverse direction; this causes undue stress on the parts and may even fracture the main or crank shaft.

In most engines the point of ignition is capable of adjustment. In this case retard the spark so that ignition will occur after the

crank passes the dead center. See that the ignition circuit, oiling gear and cooling water are in order and turned on. Open the throttle, fuel valve to carbureter if installed, prime the cylinder and open the relief cocks on the cylinders if necessary. Give the engine a few turns by the fly-wheel, if small, or the starting device, if large, and, if everything is in order, the engine will start. Opening the relief cocks relieves the compression and makes cranking easy; on the other hand, relieving the compression makes ignition more difficult. The behavior of the engine at hand will govern this point. After the engine is started, adjust the ignition to the proper lead, close the relief cocks if open, see that the oil and water are working properly, and adjust the mixture if necessary. These general instructions may be modified for different types of engines. If an engine is to stop but a few moments, the ignition circuit may be broken, if of the jump spark type with battery and coil. The few revolutions due to inertia after the spark is cut off will leave the cylinders charged with the mixture. By again closing the ignition circuit a spark will jump in the cylinder that has its piston in the firing position, and, if the mixture is still in combustible form, the engine will start without cranking. This is called "starting on spark."

To stop the engine, close the throttle, break the ignition circuit, and close the fuel valve. If exposed to freezing weather, drain engine jackets and connecting pipes. Although it has been recommended that the oil supply be shut off before the engine is stopped in order that the surplus oil may be carried out with the exhaust, the author is not in agreement. If the oil supply is properly regulated, there will not be enough surplus to cause serious clogging in the cylinder or valves, whereas the serious results that might occur if the engine were started without turning on the oil supply (as might easily happen if other than the regular hand started the engine) are obvious. Wrecks from this cause are not infrequent. In modern practice, especially where the splash system is used, the oil supply is left turned on at all times. This does not apply to heavy duty motors having special feed systems.

Failure to Start. Should the motor fail to start, the trouble can only be found by a man conversant with the interrelation of the

parts of the machine and their relative functions, and "trouble hunting" resolves itself into an investigation of the different integral systems of the motor. Of course many causes of non-starting are apparent from the behavior of the machine, and an experienced hand will generally have little trouble in finding the defect. However, occasionally a defect will baffle even an expert until he has thoroughly overhauled and analyzed the motor.

When investigating non-starting, divide the machine as follows:

1. Ignition system.
2. Fuel system.

Non-Starting Due to Faulty Ignition

First look to the spark. It may be too feeble to ignite the mixture or may not occur at all. In this case first test the battery. If this is found in good condition, test the line up to the plug for broken wires, short circuits or poor contacts. Finally look at the plug. It may be too foul for the spark to bridge, the points may be too far apart, or the insulation may be defective.

If a good spark is present at the plug, then it may be taking place at the wrong part of the cycle, due to the timer being out of adjustment. This discrepancy is made good by so adjusting the timer that the spark will occur at or just beyond the end of the compression stroke. If the spark is strong enough for ignition and is properly timed, then the trouble will be found under the second head.

Non-Starting Due to Fuel Supply

The tank may be empty or the fuel valve closed. Although this sounds childish, many operators have wasted much valuable time trying to start under these conditions. The feed pipe may be clogged. Often waste or other foreign matter find their way into the feed pipes through the tank. The throttle or the air valve may be stuck. Defective adjustment of the air valve may result in a non-combustible mixture. The carbureter may be out of order. A leaky needle valve, resulting in a flooded carbureter, is a frequent source of trouble. The compression may be defective, due to leaky or broken piston rings or valves. This is evidenced by the small

resistance encountered when cranking the engine. A broken valve stem or loose valve cam, which does not show at once, may cause a valve to become inoperative. In a new installation the tank may be too low to supply a gravity feed, or the lead of feed pipe may be bad.

Common Defects and their Causes

Back-Firing. This, one of the commonest of the defects, consists of explosions in the passages outside of the cylinder. They may be located in the exhaust pipe or passages, or in the inlet passage between the carbureter and inlet valve. In the case of exhaust passage explosions, the ignition may be too late. Combustion is incomplete when the exhaust valve opens, and some of the unburnt charge finds its way to the exhaust passage where it explodes. When governing by the hit and miss system the charge of a miss cycle may explode in the exhaust passage when the hot exhaust of the next exploded charge comes in contact with it. A mixture which burns so slowly that combustion is incomplete when the exhaust valve opens will have the same effect as late ignition.

Back-firing in the admission passage is more perplexing. A leaky, broken or badly timed admission valve may transmit the combustion within the cylinder to the fresh charge in the admission passage, causing a back-fire there. Another, and very common, cause for this form of back-firing is a too thin mixture. A very lean mixture burns slowly, and the combustion may continue throughout the exhaust stroke until the inlet valve opens, thus exploding the mixture in the inlet passage. A very rich mixture might act in the same manner, but it is more likely to cause a back-fire in the exhaust passage. A loose valve cam may cause back-firing by timing an admission or exhaust valve improperly.

Misfiring. There are two distinct classes of misfiring, continuous and intermittent. Continuous misfiring of one cylinder of a multiple cylinder engine is a simple problem. The trouble is almost certain to be in the ignition system, because the operation of the other cylinders indicates that the fuel supply is operative as far as the admission valve of the defective cylinder, and were trouble located in the valves of the defective cylinder it would generally be

accompanied by back-firing. If the valves are found to be functioning correctly then the ignition system must be overhauled. The system must be operative as far as the coil because if it were defective in the battery or primary line to the coil all the cylinders would fail to fire. Among the ignition defects that might cause misfiring in one cylinder are foul or defective plug, broken wire or bad contacts, or improperly adjusted coil vibrator. These are all easily found by simple electrical tests.

Intermittent misfiring may be caused by improper mixture, weak battery, poorly adjusted coil, broken wires or connections that are in contact intermittently due to the vibration of the engine, dirty sparking device, admission valve, if automatic, not working freely, exhaust valve not closing every cycle, leaky valves and poor compression, or water in the gasoline.

Carbureter explosions have the same origin as admission pipe back-firing.

Muffler explosions have the same origin as exhaust pipe back-firing.

Weak explosions are due to late ignition, weak battery, poor quality of the mixture, insufficient compression, or loss of compression due to leaky or broken piston rings or valves. Overheating may give weak explosions and attendant loss of power due to the dissociation of the mixture to its elements.

Overheating may be occasioned by one of three defects, excess friction due to poor adjustment of bearings, etc., defective circulating water supply, or failure of the lubricating system. The water supply may fail totally or partially due to pump breakdown, clogging of the pipes, closed valve in the line, or sediment on the cylinder walls. When the water supply fails the temperature quickly rises high enough to burn the oil and damage ensues, the piston rings and cylinder walls wear and the piston will ultimately seize. Failure of the oil supply if not discovered early results in the same serious trouble. Serious overheating is attended by loss of power and this

is an early indication that should be a warning signal to an experienced man.

Knocking may be due to mechanical trouble such as loose bearings, etc., or to explosive defects. Under the latter head there are two recognized classes of knocks, a "gas knock" and a "spark knock." A gas knock is caused by too rich a mixture or by opening the throttle too quickly. It is an infrequent phenomenon. A spark knock is caused by advancing the spark too far. A slight pre-ignition occurs, and though it is not early enough to cause reversal of the engine rotation, it puts undue stress on the parts and causes a tinny thump. Carbon deposits will cause knocking in the cylinder. Near the end of the compression stroke these become incandescent and premature ignition results.

Crank chamber explosions in a two cycle engine are caused by a thin mixture or a retarded spark. In either case combustion is not complete when the admission port is uncovered and the burning gases come in contact with the fresh charge in the admission pipe igniting them. The explosion transmitted through this pipe to the crank chamber may be a source of much annoyance, for frequently the crank case cover gasket is blown out and must be replaced to keep the case gas tight.

A smoky exhaust indicates too rich a mixture or an excess of lubricating oil. In the latter case the exhaust is black or dark brown, burnt oil vapor being present. In the former case the exhaust is generally hazy and lighter and carries the pungent smell of unburnt fuel.

Lost compression may be due to improper lubrication. An important point that is often overlooked is that the film of oil between the piston ring and cylinder forms a packing, and, if this is not perfect, the gas will leak by on the compression stroke. This is technically known as "blowing." Other and more frequent causes of loss of compression are overheating, leaky or broken valves or rings, leaky spark plug gaskets and relief cocks, and scored or worn cylinder walls.

Premature ignition may be produced by advancing the spark too far, too high compression, overheating, overloading the engine, or

by carbon deposits on the piston or cylinder heads becoming incandescent. The remedies are obvious. Carbon deposits must be removed periodically. This is generally done by scraping, although there are several reliable solutions on the market for this purpose.

Carbureter defects are common and numerous. The needle valve may leak and flood the gasoline chamber. This will cause a very rich mixture, and can be remedied by grinding the valve. The air valve or throttle may become stuck. The auxiliary air valve spring may not be properly adjusted to give the correct mixture at high speeds. Water may accumulate in the float chamber, if present in the gasoline. A drain cock is generally provided to avoid this difficulty. The spray nozzle may clog if there is dirt in the gasoline. Gasoline should be thoroughly strained through chamois before putting it into the tank. This will remove all dirt and water, if carefully done. A thorough knowledge of the carbureter is essential for successful operation of any internal combustion engine.

General

Long and Short Stroke Motors. The proportion of cylinder diameter ("bore") to stroke is a problem that has caused more discussion and resulted in less uniformity of opinion than any other subject in the internal combustion engine field. Although no distinct line is drawn a motor that has a stroke exceeding $1\frac{1}{2}$ times the bore is generally spoken of as a "long stroke" motor, and any having a smaller ratio, as a "short stroke" motor. As the advocates of both types lay claim to every conceivable advantage, the subject will not be discussed here other than to say that increasing the stroke increases the expansion and also the loss by radiation due to the longer contact of the gases each stroke with the cylinder walls. It increases the piston speed; and reducing the bore to maintain the same power, it increases the ratio of cylinder wall to cylinder contents, hence increases loss by radiation.

The duty for which the motor is designed, the necessary piston

speed, power required, weight allowed and initial compression, must regulate the bore and stroke to a large extent.

Clearance. The clearance volume is the space enclosed by the piston head, cylinder walls and valve recesses, when the piston is at the beginning of its stroke. The proportion of the clearance volume to the piston displacement is much higher than in the steam engine, because all the medium is present in the cylinder at the beginning of the stroke instead of being admitted during a fraction of the stroke as in the steam engine. This statement does not apply to the Diesel and similar oil engines. Its value depends upon the kind of fuel used, sometimes exceeding 35 per cent. Obviously the higher that the fuel can be compressed, the less clearance that will be necessary.

Stratification Theory and After Burning. This theory advanced by Otto and so vigorously defended by Slaby during the Otto patent litigation assumed that in a four cycle cylinder the charge was so distributed that practically nothing but burned gases were next to the piston (scavenging being imperfect), next a layer of poor mixture, and finally near the igniter the full strength of the mixture. It was further assumed that this arrangement was not disturbed during compression. Ignition was sure, but combustion was not completed until the piston had reached some point along the expansion stroke. Thus Otto accounted for the slow drop in the expansion line, and called it "after burning."

In view of present information, it is shown that, although stratification is not impossible, it does not affect the economy or performance and as a factor it is not considered in design or theory. The phenomenon of after burning has also been explained by the "dissociation theory." At a certain temperature limit a composite gas breaks up into its elements, and at this temperature limit combustion cannot take place. If this limit is reached at the maximum compression, combustion will not occur until the piston has reached such a point on the expansion stroke that the pressure and temperature has fallen below the critical or dissociation point. Consequently combustion takes place along the expansion line resulting in the phenomenon of after burning.

Scavenging. Scavenging a cylinder consists of driving out the burned gases before, or simultaneous with, the entrance of a new charge. This is very imperfect with an ordinary four cycle motor, for, at the instant of admission, *all* the clearance volume is full of the burned gas. Those engines which receive the air and fuel separately can be scavenged thoroughly by admitting the air while the exhaust port is still open and driving out the exhaust gases by

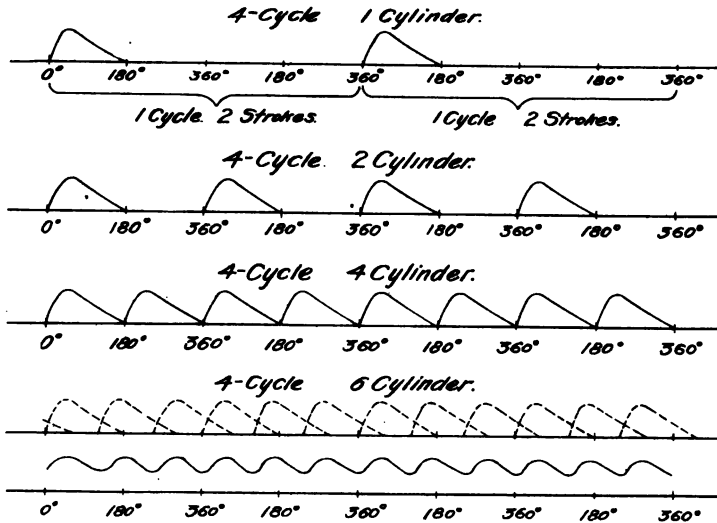

FIG. 58.—Pressure Diagrams, Showing the Effect of Multiplying Cylinders.

this air before the fuel valve opens. Two cycle engines require thorough scavenging. A study of the cycle shows that upon this depends the volume of fresh mixture that can be taken into the cylinder, and as the two cycle exhausts just past the center of the expansion stroke, instead of at the end as in the four cycle, scavenging is of more importance in the former case. This is generally accomplished by allowing some of the fresh charge to enter while the exhaust port is still open. A proper design of exhaust will aid scavenging by giving the exhaust gases a high speed, causing a tendency toward a partial vacuum in the exhaust line.

Pressure Diagram. The diagrams in Fig. 58 show the effect of

multiplying the cylinders of an engine. They are constructed by superposing the cards of a one cylinder engine in the appropriate phase of two successive cycles. Similar diagrams can be made for two cycle engines. The upper line, which represents the pressure acting during two complete cycles, shows 1080° or six strokes of idle effort during two cycles. The second line, which represents a two cylinder engine, shows that pressure is acting 50 per cent of the time. It is not until we compound to six cylinders that we obtain an overlapping pressure.

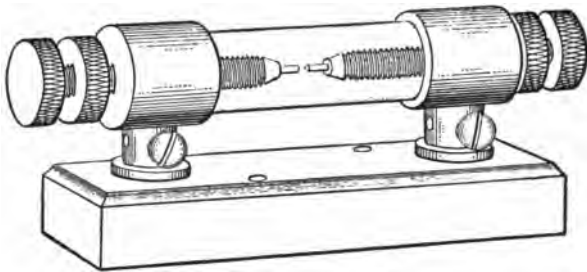

FIG. 59.—Secondary Spark Gap.

Secondary Spark Gap. (Fig. 59.) This is a spark gap placed in the secondary circuit just outside of the cylinder. It acts as a condenser, building up the pressure on the terminal until it can leap the air gap, thus raising the pressure in the circuit and strengthening the spark at the plug. The advantages are:

a. Greater certainty of sparking, because the built up potential will jump a partially fouled plug.

b. A means of inspecting the spark in the cylinder is provided, for a spark across the gap means a spark at the plug.

Although not generally adopted at present, the author believes that such a device could be advantageously employed in the larger multiple cylinder engines. By wiring one auxiliary gap so that it could be cut into the secondary circuit of any cylinder at will, a ready means of testing the spark at any plug is at hand, and all

work of dismantling the sparking apparatus at the engine for purposes of inspection is obviated. Although this would increase the high tension wiring, no current would be flowing in the additional wire except during the short interval of testing.

A ready means of inspecting the spark in large stationary gas plants is furnished by wiring an incandescent lamp in series with each spark plug. Failure of this lamp to light each cycle indicates absence of a spark at the gap.

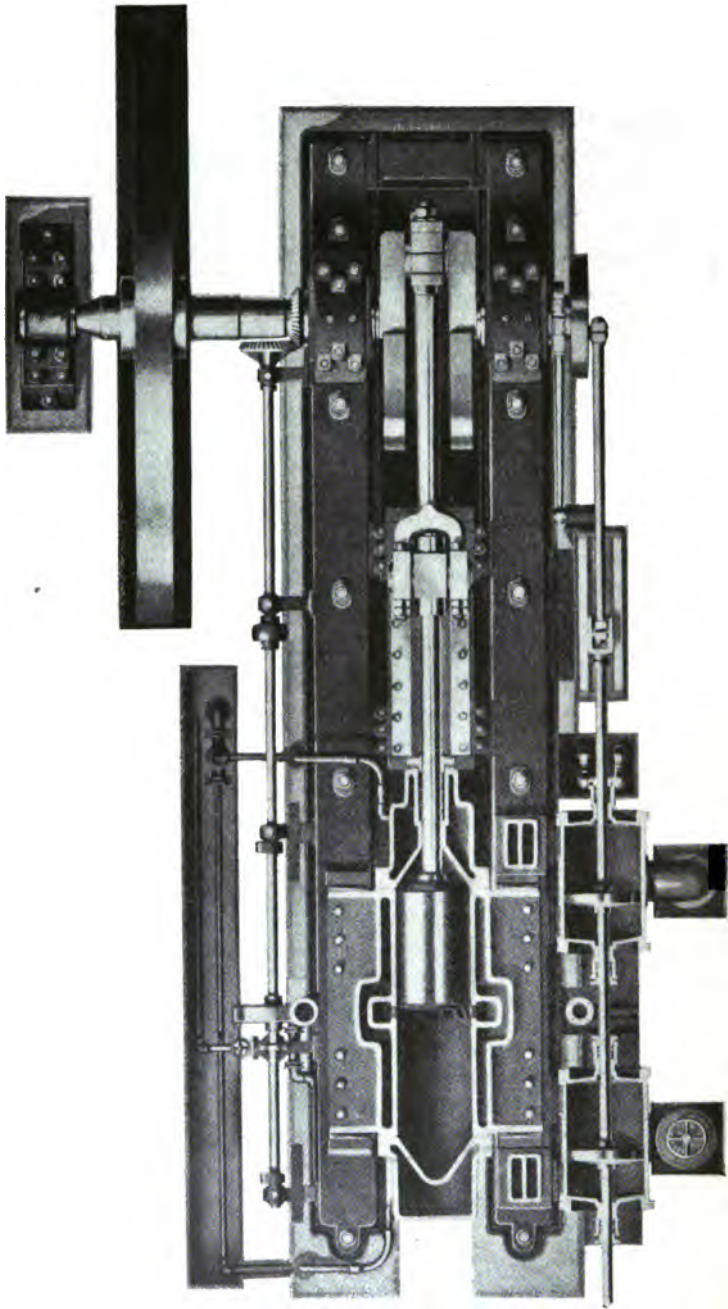

FIG. 60.—Koerting Two Cycle Gas Engine.

CHAPTER X

ENGINES

The Koerting Two Cycle Gas Engine

This engine illustrates the two cycle type with separate charging pumps. It is double acting like a steam engine and therefore the ends of the main motor cylinders, the connecting rods, cranks and other mechanism for transmitting power from the expanding gas to the engine shaft are capable of design similar to that used in steam engine practice. The novel feature is the mechanism which controls the admission of the combustible gas to alternate sides of the main piston. These valves and pumps are explained in detail later.

The Koerting Cycle

The various steps of the cycle are taken up in the order in which they occur.

1. The Exhaust. In the position shown in Fig. 60 the piston is at the end of its out-stroke and has just uncovered the exhaust ports shown in the middle of the cylinder through which the products of combustion escape to the atmosphere. The escape of the exhaust is hastened by the admission of a quantity of air known as the scavenging charge, which, being introduced under pressure behind the burned gases, displaces them during the time that the ports are uncovered by the piston.

2. Admission. At this point the charging pumps, shown at the side of the cylinder and described more fully later, supply the cylinder with a fresh charge of air and gas which is compressed on the return stroke and ignited to do work on the next succeeding out-stroke. The function of the pumps is to measure, and supply at the proper instant, the right proportion of gas and air necessary for perfect combustion in the motor cylinder. The charge is delivered at a pressure of about four pounds.

3. Compression. During the return or in-stroke the admission valve is closed, the exhaust ports are covered by the piston and the combustible charge of air and gas thus confined in the cylinder is compressed by the returning piston into the pre-determined clearance space left between the end of the piston and cylinder head at the end of the compression stroke.

4. Ignition. At the instant that the engine passes the dead center the charge is ignited and the expansive energy of the burning gases is exerted directly on the piston. The engine being double acting, the same operations take place in the opposite end of the cylinder, compression taking place at one end, while expansion is going on at the other end. From the foregoing it is apparent that the Koerting cycle is on the two cycle principle.

The two operations of expelling the products of combustion and admitting the fresh charge are accomplished during the interval of time that the piston leaves the exhaust ports uncovered as it passes the dead center. The pressure of the incoming gas being low this can be accomplished without the loss of an appreciable amount of gas and with only a small loss of power, the only requisite being that the air which forms the scavenging charge must be so introduced as to spread evenly over the whole area of the cylinder, forming a separating layer between the combustible mixture and the products of combustion of the preceding charge. This stratification of the gas is accomplished by means of specially designed surfaces located in each cylinder head just under the admission valves. It prevents all possibility of misfire and pre-ignition. These surfaces impart a whirling motion to the air and turn it back upon itself in such a way that it forms an equally distributed layer over the entire area of the cylinder.

Valve Group and Pumps

There are no exhaust valves. The admission valves, one on each end of the cylinder, as shown in Figs. 61 and 62, are of the poppet type positively actuated by means of levers and push rods from cams on the main valve gear shaft, which, in turn, is driven by miter gearing from the main engine shaft. The fresh charge of gas and

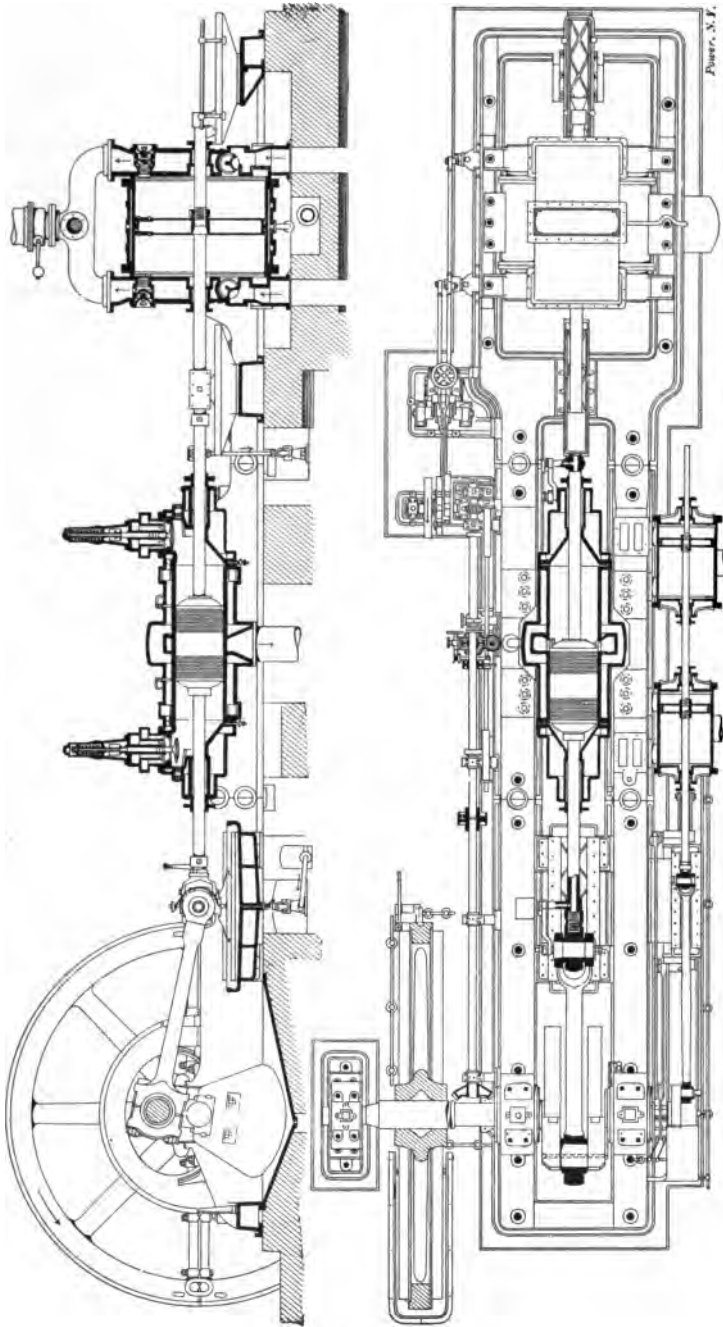

FIG. 61.—Koerting Two-Cycle Gas Engine, Showing Valve Group.

air is supplied by two charging pumps shown in Fig. 62. These pumps are driven by a crank and connecting rod from the main crank shaft of the engine and the pump discharge valves are driven from eccentrics on the main shaft. Each end of each pump discharges into a separate duct; and these ducts, which pass through the main engine frame, convey the gas and air from the crank end of their respective cylinders to the crank end of the main cylinder, and

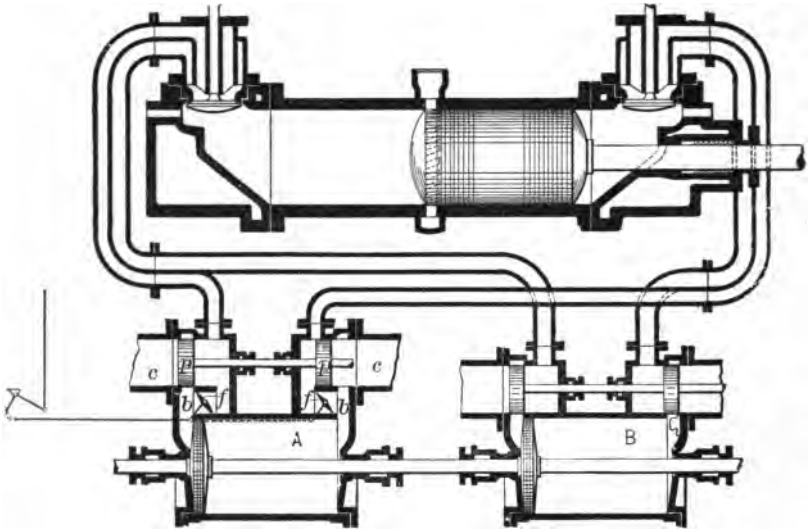

FIG. 62.—Valve Group of Koerting Two Cycle Gas Engine.

- | | |
|-----------------------------------|---|
| <i>A</i> , gas pump. | <i>c, b</i> , gas admission to pump. |
| <i>B</i> , air pump. | <i>f</i> , gas discharge from pump to cylinder. |
| <i>p</i> , pump discharge valves. | |

from the head ends of these cylinders to the head end of the main cylinder, as indicated diagrammatically in Fig. 62.

As shown in the figure, one gas and one air channel terminate in an annular opening concentric to and just above each admission valve; the inside duct leading to the gas cylinder and the outside duct leading to the air cylinder. In order to secure a separating layer of air between the burned and fresh charges the gas pump valves are so fixed that no gas is delivered until after a certain point

in its compression stroke, while the air piston delivers throughout its entire stroke. The air, commencing to be discharged before the gas, passes through its discharge duct, encounters the closed admission valve and starts back towards the gas cylinder through the gas duct, pushing the gas before it. When the admission valve opens, both ducts at first discharge air, and later the one air and the other gas. The air first discharged forms the scavenging charge and the mixture of air and gas which follows, the combustible mixture. Since the discharge of gas and air is through separate ducts terminating only in the mixing chamber above the admission valve, no explosive mixture is formed until this valve opens to admit the fresh complement of air and gas to the main cylinder.

General. The walls of the main cylinder, cylinder heads and stuffing boxes are cooled by water circulation. The cooling of the piston is also effected by water which is introduced through the hollow cross-head pin and piston and returns through a pipe inside the hollow piston rod. Ignition is by the make and break system, the source of current being by a high tension oscillating armature magneto, one for each end of the cylinder. This form of magneto facilitates starting, for one oscillation is sufficient to start. The moving parts of the ignition plugs are operated by a small shaft parallel to, and driven by, a spur gear from the main valve gear shaft. The point of ignition is adjustable.

The engine is started by compressed air. A piston valve is provided for admitting the compressed air to the front and back end of the cylinder alternately, just as similar valves admit steam to a steam engine. This piston valve is operated from the cam shaft by an eccentric, and the gear can be thrown into operation or stopped instantly by means of a special clutch. The manufacturers claim that the engine can be started in 30 seconds. When starting the engine works like a steam engine, making two or three revolutions on compressed air, after which gas is admitted and the compressed air shut off.

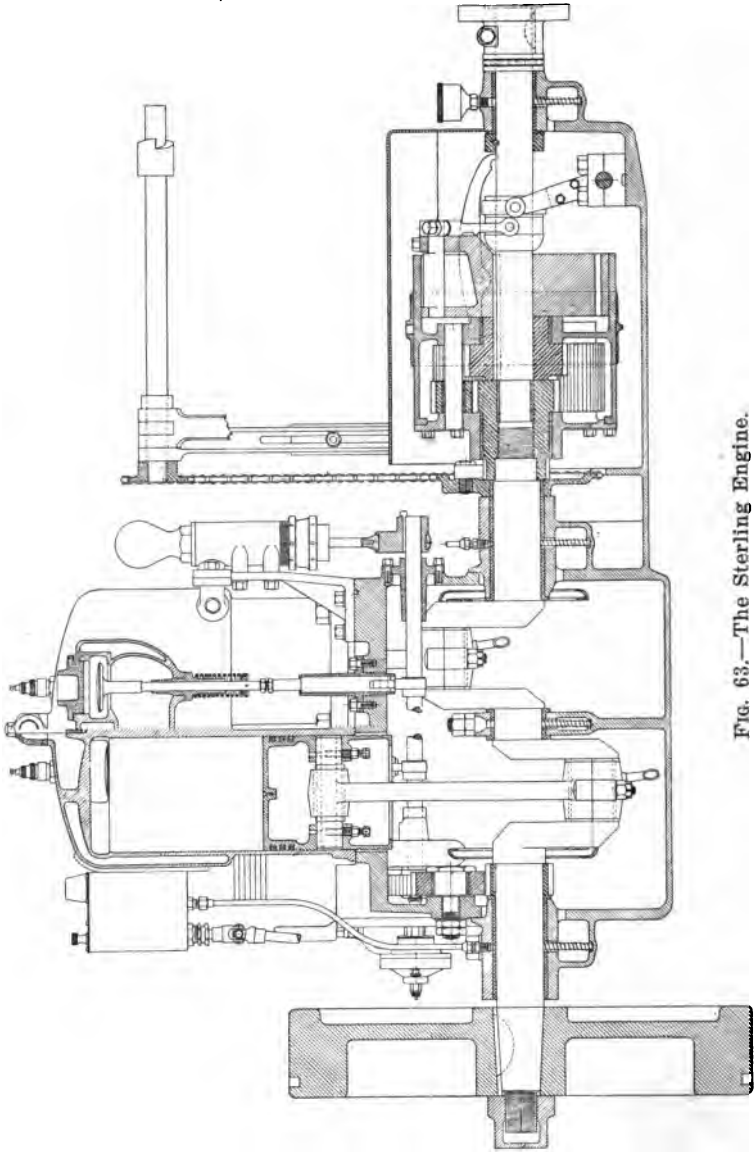

FIG. 63.—The Sterling Engine.

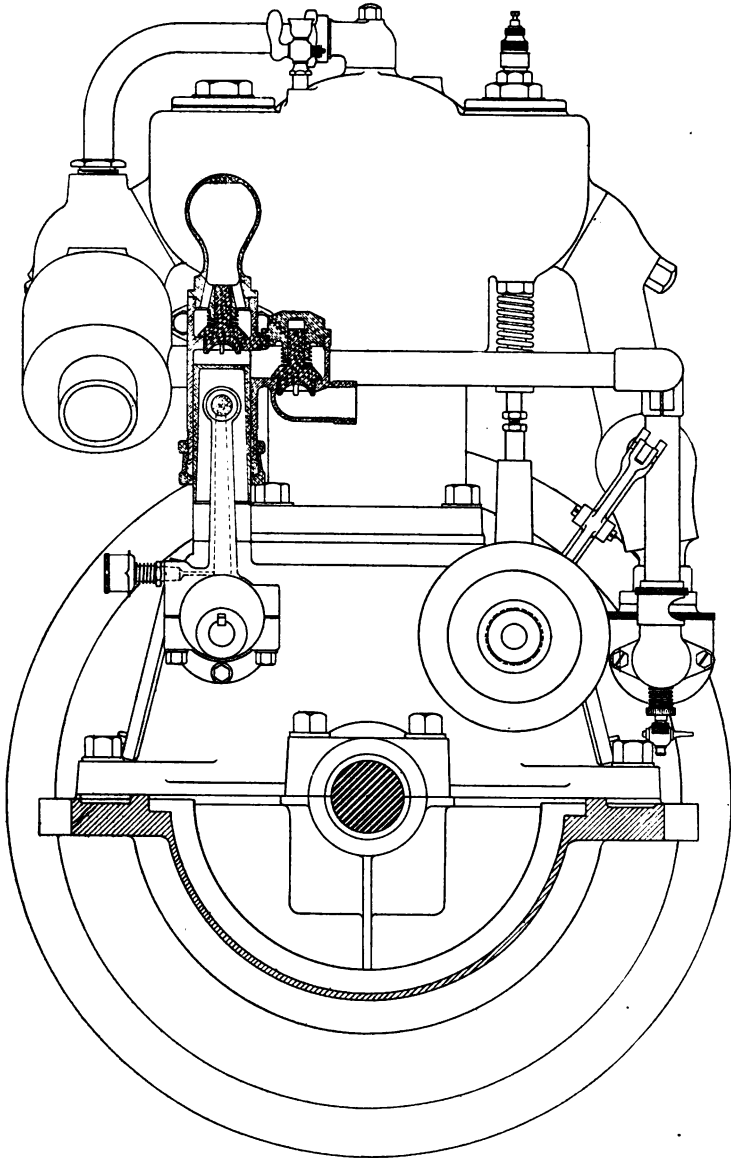

FIG. 64.—The Sterling Engine.

The crank shaft is made of carbon steel. All bearings are ground to size within .0005 inch in diameter and .002 inch in length. The forward end is turned taper and has a key-way cut for attaching the fly-wheel. The crank shaft has three main bearings and this is known as "three point suspension."



FIG. 66.—Connecting Rod.

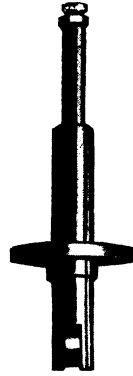

FIG. 68.—Push Rod.

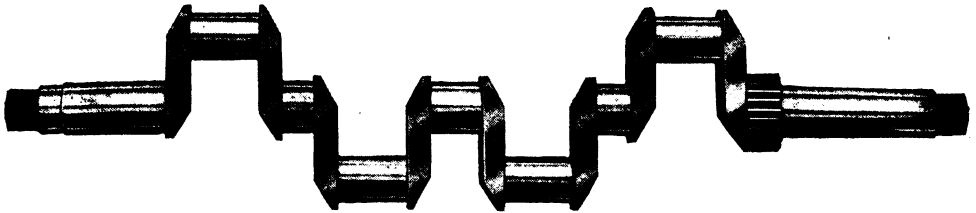

FIG. 67.—Crank Shaft. Three Point Suspension.

The push rods which operate the valves are of steel. The lower end receives the hardened steel roller which bears directly on the cam. These rods are fitted with adjustable screws which admit of adjustment of the valves without disturbing any other parts. Push rod guides are of hard bronze, supporting the push rod nearly its entire length. This guide is secured to the engine base by stud bolts.

The water circulating pump is of the large plunger type and expansion joints are used on the water connections. The exhaust manifold is water-jacketed its full length.

The lubrication system is mechanical. Oil is pumped from the reservoir through the tubes to the oil rings and the cam gears, and from there flows to the base, maintaining the necessary level of oil for the splash system that is used for the cylinders.

The lower base is divided into pockets by partitions between the connecting rods. This maintains a constant level of oil regardless of the pitching of the boat. Without these partitions all the oil would run to the end of the engine that is temporarily lowest. The crank pins are lubricated by oil which enters the scoop and passes through a duct in the connecting rod cap.

Ignition is by the jump spark system.

The Standard Engine

This gasoline engine designed for marine use is made in units of three cylinders, and generally installed as a two unit plant or six cylinder engine. It is four cycle, double acting, having an admission and exhaust valve for both top and bottom of each cylinder. This gives the engine the equivalent of twelve working cylinders. The engine is water cooled, as are all the pistons, connecting rods, valves, and the exhaust manifold.

The admission valves are all on the front of the engine, and are mechanically operated from the same cam shaft. The exhaust valves on the back of the engine are similarly operated by another cam shaft. All valves are mushroom shaped of the balanced type.

To reduce the power to one-half all the *bottom* admission valves can be locked closed and the exhaust valves open, making the engine six cylinder single acting. To reduce to one-fourth power the two units can be disconnected and one unit run as a three cylinder single acting engine. The engines are built to 250 horse-power per three cylinder unit. A twin screw marine plant of 1000 horse-power can be furnished by the manufacturers.

The piston is short, being somewhat similar to a steam engine piston, and a cross head and guide are present in consequence. The piston rod works through a metallic packed stuffing box to make the bottom end of the cylinder gas tight. The oiling and cooling systems for such a large engine are necessarily elaborate, but these

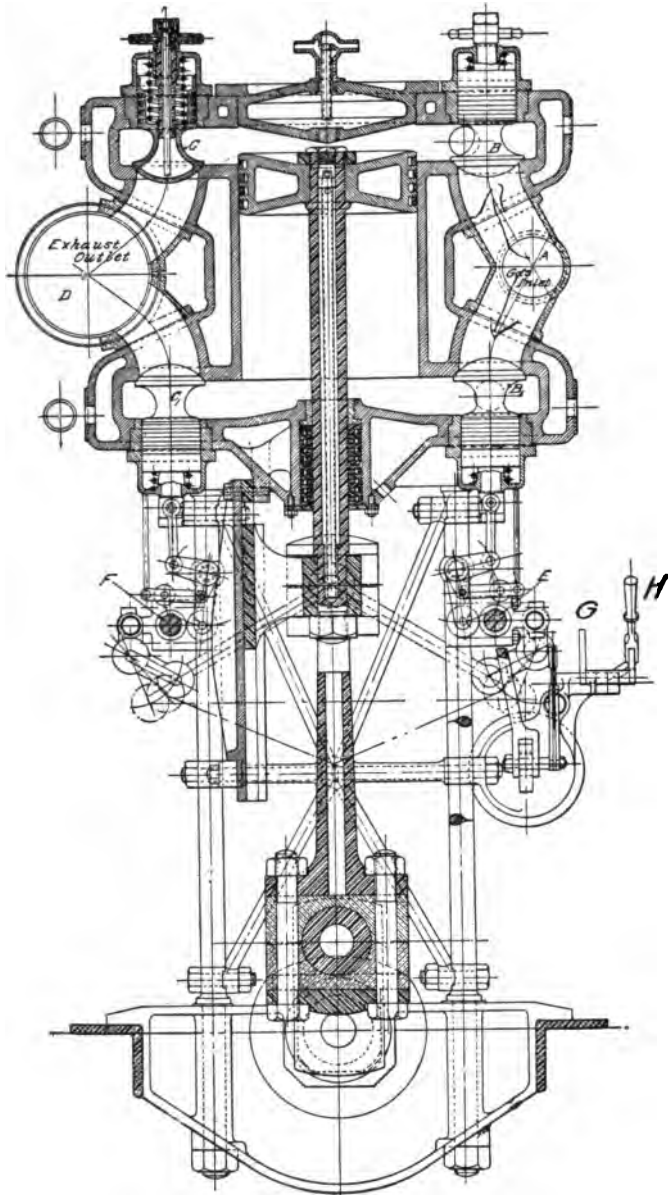

FIG. 69.—Standard Engine.

difficulties are cleverly overcome, and, due to good design, the engine is quiet and free from vibration. Lubrication is by the forced feed system.

In Fig. 69, *A* is the gas inlet, *B* the top admission, *C* the top exhaust, and *D* the exhaust outlet. It is apparent that this will operate as a four cycle engine. On the bottom end, *B*₁ is the bottom admission, and *C*₁ the bottom exhaust. This end also acts as an independent four cycle engine. *E* and *F* are the cam shafts that operate the admission and exhaust valves respectively.

Ignition is by the make and break system.

The admission pipe runs along the center line of the cylinders in front of them and sends a branch to each end of each cylinder. The engine is operated by the two levers *G* and *H* shown on the front of the engine. *G* is the spark lever. The lever *H* operates a compressed air valve which, in turn, can shift the admission valve cam shaft in the direction of its length. This shaft carries three sets of cams. One operates the admission valves for the ahead direction, one for the reverse direction, and one set operates air valves in the bottom of the three after cylinders for starting and reversing.

To start, shift the cam shaft so that the three after cylinders work on compressed air. The three forward ones are on gasoline. After a few revolutions on air the forward cylinders will start to run by fuel. Shift the lever until all the cylinders are on gasoline.

To reverse from the go-ahead direction, shift the shaft part way over so that the air valves are in operation. Shut off the fuel and open the air throttle. As soon as the engine is started in the reverse direction by the air, start on fuel and throw the lever all the way over to the reverse direction. When the air valve cams are operating the air valves on the bottom of the three after cylinders, other cams are holding the top exhaust valves of these cylinders open.

The Gnome Engine

The Gnome engine is built in two sizes, 50 horse-power and 100 horse-power. A 140 horse-power engine is being constructed for the Gordon Bennett cup race. It is used for aeroplanes exclusively. The 50 horse-power (Fig. 70) has 7 cylinders and the 100 horse-

power has 14, 7 being in one plane and 7 in a parallel plane, those of the second group being staggered with those of the first. It is a gasoline radial, rotary, air cooled engine. The crank shaft is stationary and the cylinders revolve about it. This gives the same relative motion of the pistons to the cylinders as if the cylinders were stationary and the crank revolved. The crank shaft is secured to the aeroplane. The propeller is made fast to the front of the cylinders and revolves with them.



FIG. 70.—Gnome 50-H. P. Engine.

The carbureter is in the rear of the engine and the charge passes through the hollow crank shaft to the crank case. Automatic inlet valves in the piston heads admit the charge to the cylinder. The exhaust valves which are in the cylinder heads are mechanically operated from the shaft and the ignition circuits to the plugs are also completed by contacts on the shaft. Ignition is by a high tension magneto and the point of ignition is not adjustable by hand. At low speed the spark is retarded and as the engine speed is increased the spark is advanced automatically by the consequent increase of speed of the magneto. Lubrication is by forced feed. The cylinders are made of solid steel and are secured to the crank case by an ingenious ring. Experiments are being conducted with an engine of this type having mechanical inlet valves.

Knight Slide Valve Motor

The poppet type of valve has been used in all practical four-cycle internal combustion engines until recent years, but the adoption after exhaustive tests of this motor in the Stearns and Columbia automobiles in this country, and the Daimler and numerous others abroad, has again drawn attention to slide valve construction. The difficulty of keeping the ordinary slide valve gas tight and of providing sufficient lubrication at the high working temperature of the gases has made its use impractical.

The impact of poppet valves on their seats, and the cams, springs, etc., which operate them, are the source of noise in an engine. This noise is eliminated in the Knight motor. The principal advantage claimed for this valve mechanism is that the inlet and exhaust passages are fully twice the size of the gas passage obtainable in a liberal design of the tee-head poppet valve motor, and nearly three times the size of the gas passages in the ell-head or valve-in-head motor.

Figs. 70a, 70b and 70c show the general features of design as adopted by the United Motor Company in the Columbia. The cylinder heads are removable. They are depressed, water-cooled and contain two spark plugs for Bosch or other double ignition. The valves for each cylinder consist of two sleeves made of Swedish grey iron. Being very thin there is no limit to the degree of hardness attainable. Both inner and outer sleeves are open at both ends and each sleeve has openings on two sides. These sleeves are reciprocated to perform the valve function by short connecting rods actuated by a lay crankshaft at half speed by "Coventry" silent chain.

As seen from the cuts the outer sleeve, driven by a connecting rod from a countershaft on the right, Fig. 70b, moves up and down between the cylinder wall and the inner sleeve. The inner sleeve, driven by its connecting rod from the same countershaft, Fig. 70a, moves up and down between the outer sleeve and the piston. The inner wall of this inner sleeve forms the combustion chamber wall.

The travel of the sleeves is only about one inch and the power required to overcome their friction and drive them is no greater than that necessary to actuate poppet valves for an engine of the same size.

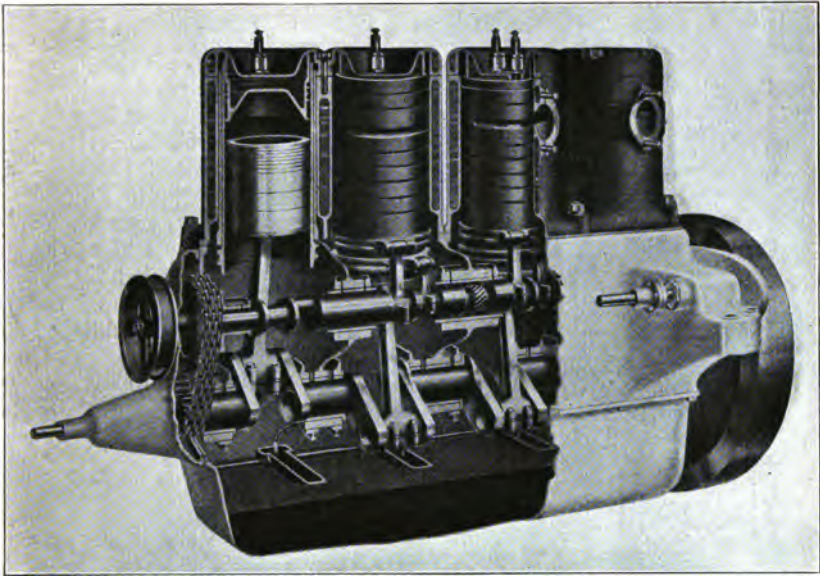

FIG. 70a.—Columbia Knight Motor, Showing Sleeve-Valve Arrangement.

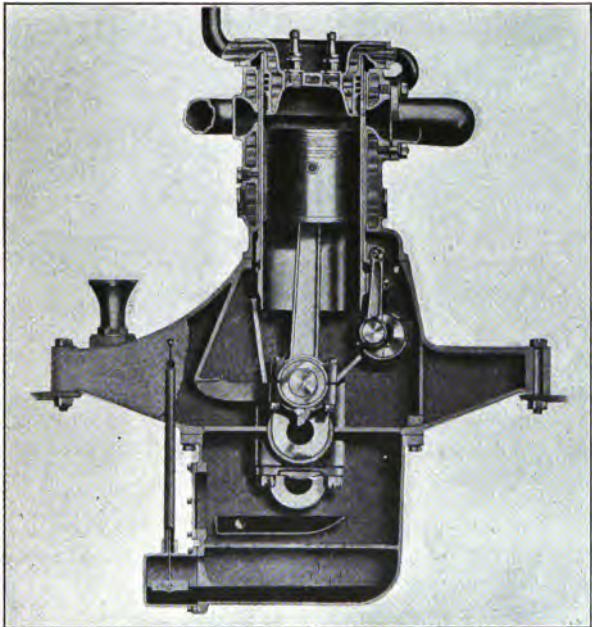

FIG. 70b.—Columbia Knight Motor, Cross-Section View.

Operation. During the suction stroke the right-hand slots of the inner and outer sleeves register, forming a large opening for the charge to enter. At the end of the suction stroke one sleeve moves up and the other down, closing the opening, and the compression stroke takes place. Compression being accomplished the charge is fired in the usual way and the combustion or power stroke takes place, all slots still being out of register. At the end of the power stroke, movement of the sleeves brings the left-hand slots into register, and the opening thus formed is a large exhaust for the gases. This is best illustrated by Fig. 70d, which is published by courtesy of the *Scientific American*.

The eccentric operating the inner sleeve is given a certain advance or "lead" over that of the outer sleeve. This lead, together with the rotation of the eccentric shaft at half the crank shaft speed, produces the cycle of operations.



FIG. 70c.—Details of the Columbia Knight Motor.

In the first diagram, Fig. 70d, the piston is just past its top center, and is starting down on the inlet stroke. The inner sleeve is at the bottom of its travel and moving slowly upward, the outer sleeve is about midway in its travel and is moving downward rapidly. The opening from the carburetor through the inlet port into the cylinder is a rapidly increasing space between the upper edge of the slot in the inner sleeve and the lower edge of the slot in the outer sleeve. By the time the piston is a little more than half way down on the suction stroke the inlet passage is wide open as shown in the second diagram of Fig. 70d. The outer sleeve is now at the bottom of its stroke and moving very slowly, the inner sleeve is gaining in speed moving upward, and the inlet is closed by the lower edge of the inner sleeve slot passing the upper edge of the outer sleeve slot, as

shown in the third diagram of Fig. 70d. The inner sleeve continues to move up with the piston on its compression stroke, the rings in the head and piston tightly sealing the compression space, until the explosion occurs. The sleeves and piston are then in the position shown in the fourth diagram. About two-thirds of the way down on the explosion stroke of the motor the exhaust passage begins to open. The inner sleeve is moving down with the piston, and the passage is between the lower edge of the inner sleeve slot and the lower edge of the junk-ring in the head, the outer sleeve being practically stationary at the top of its stroke. The outer sleeve starts on its downward stroke, and, gaining in speed as the inner loses, leaves a clear opening for the exhaust. The piston is now one-third up on its exhaust stroke, and the passage is closed by the upper edge of the outer sleeve slot in passing the lower edge of the exhaust port in the cylinder, as the piston reaches its top center.

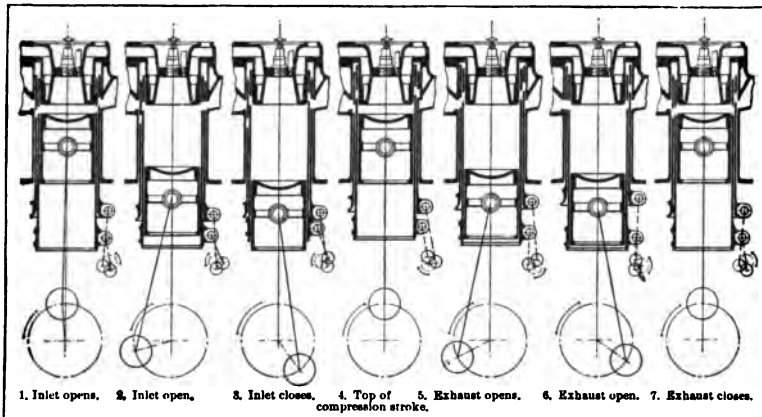

FIG. 70d.—Relative Positions of Sleeves and Piston in the Operation of the Knight Engine.

The four cycles or strokes of the engine (suction, compression, explosion, and exhaust) have now been completed; the crank has turned twice; the eccentrics have driven the sleeves once, and the cycle of operation is now ready to be repeated.

The timing shown is not different from that ordinarily used in poppet valve engines. Any timing of the valves can be secured, however, by varying the "lead" between the eccentrics that operate the two sleeves and by properly locating the slots in the sleeves. The amount of valve opening is practically unlimited and is governed by the width of the slot in the sleeves and the "throw" of the eccentrics that drive and determine the travel of the sleeves.

Lubrication. Oiling by the Columbia movable dam system insures the exact amount of lubricant that the motor speed demands. Oil is forced into the main bearings by a pump. The same pump

forces oil into troughs set transversely beneath the connecting rods, and the rod scoops dipping into these troughs splash oil to the cylinders and sleeves. These troughs are connected to a buss shaft

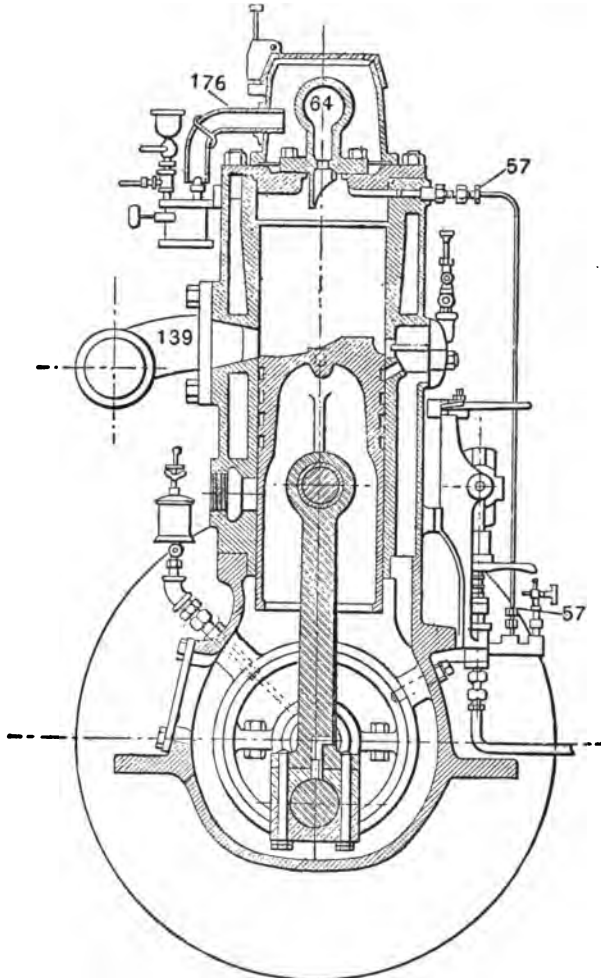

FIG. 71.

which, being operated by the throttle, raises or lowers the troughs as the throttle is opened or closed. The troughs therefore hold more or less lubricant and the scoops dip in deeply or lightly as the motor runs fast or slow.

Lubrication experiments are under way, and probably in the near future the design will embody means of supplying oil to the tops of the sleeves by forced feed. Circumferential grooves on the

outer surface of the sleeve divides this surface into a series of oil rings, thus aiding lubrication.

As this may possibly be the ultimate type of gasoline engine, experiments along this line should be watched with interest.

The Mietz and Weiss Marine Oil Engine

The Mietz and Weiss marine oil engine operates on kerosene, fuel or crude oil; the fuel is injected directly into the cylinder. The manufacturers claim a consumption of one pint of oil per horsepower hour under full load and a decrease in consumption in almost direct proportion to the decrease in load plus the idle consumption (amount required to overcome friction). It is a form of two cycle engine receiving one impulse every revolution.

Fig. 71 shows a cross section of the engine. The piston is of the trunk pattern fitted with cast iron packing rings. The cylinders

are amply water-jacketed; the circulation is by a rotary pump driven by gear from the main shaft. Circulating water enters the base of the jacket, is forced up to the top and is led into the exhaust pipe to prevent overheating of the latter. This is a common marine practice.

Fuel is supplied by a pump which is regulated by a governor so that the amount of fuel supplied is a function of the speed and load. The fuel enters the cylinder by the pipe 57 and encounters the hot

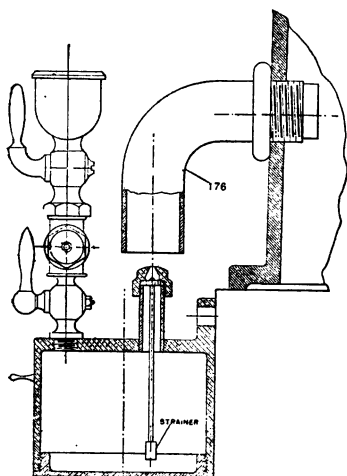

Sectional View of Starting Lamp Showing Burner and Blowpipe.

FIG. 72.

bulb 64, which vaporizes and ignites it. Waste gases pass out at the exhaust 139. When the engine is to be started cold the bulb must be heated to dull red heat by an external burner 176. The details of this arrangement are shown in Fig. 72. After the first explosion the bulb will retain its heat and the ignition is by a combination of compression and hot bulb.

Lubrication is by the forced feed type, the oil pump consisting of a plunger worked by a ratchet, the lubrication of the cylinder, piston, crank pins, shaft bearings and connecting rods being absolutely automatic. An engine of this general type is installed in the laboratory.

The American Diesel Engine

This engine, the invention of Mr. Rudolph Diesel, of Munich, received most of its early development in this country. It is a vertical, four cycle, single acting engine, Fig. 73. The manufacturers claim that it has "double the efficiency of the most perfect triple expansion engine, and *fifty per cent* greater than the hitherto best gas or oil engine." This type could be made very suitable for marine use.

It differs from all previous internal combustion engines in compressing a *full charge of air* to a point above the ignition point of the fuel, then injecting the fuel for a certain period (variable according to the load) into this incandescent air where it burns with limits of temperature and pressure under perfect control. Instead of a sudden explosion, the action is a steady combustion at a pre-determined temperature, the combustion line being practically an *isothermal*.

Fuel is pumped to the fuel chamber by a fuel pump. A two stage compressor, generally driven from the main shaft, serves to compress air to about 800 pounds pressure. This air is cooled before use, and is used only to inject the fuel from the fuel chamber to the cylinder, and to charge an air tank for starting the engine when cold. An extremely sensitive governor controls the quantity of fuel injected each stroke. So fine is this regulation that the engine is used to operate alternating current generators in parallel without difficulty.

The fuel used at half load rarely exceeds 55 per cent of that used at full load, so the consumption is nearly proportional to the work done. This very marked contrast to the performance of other types of engines is the result of features inherent in the Diesel cycle alone, and is due to direct regulation of the fuel supply by the governor. The engine is *guaranteed* a consumption not to exceed 8 gallons of

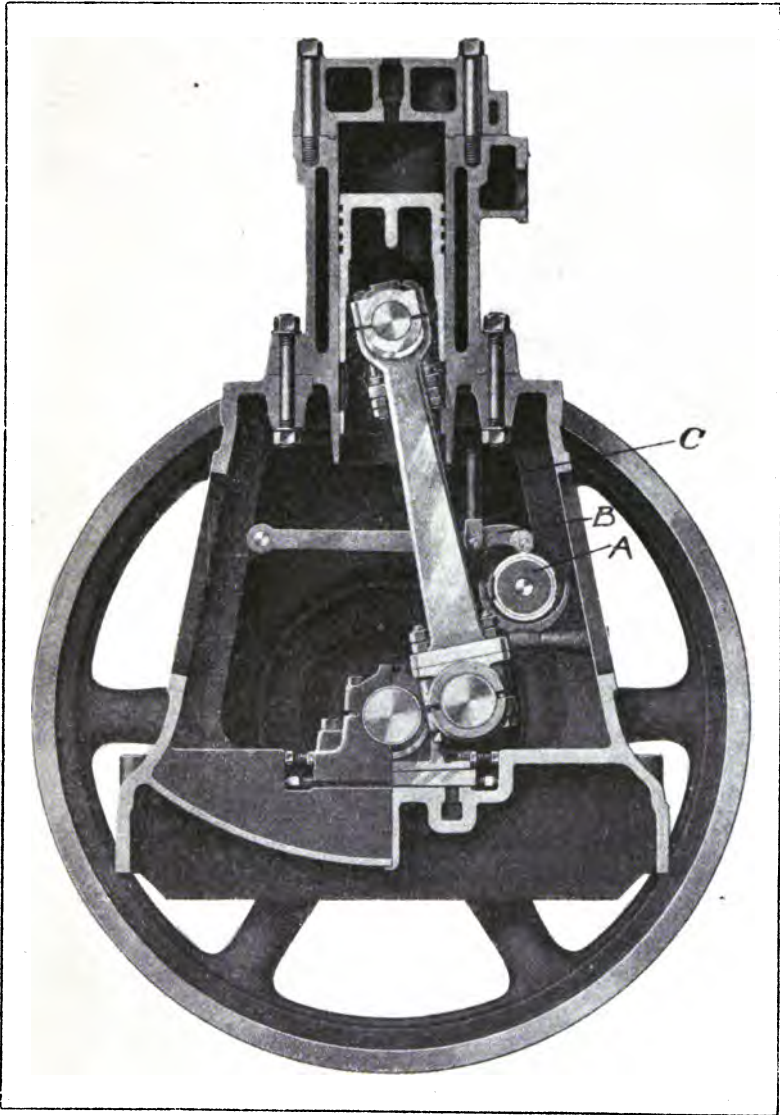

FIG. 73.—Diesel Engine.

suitable crude or fuel oil for each 100 net effective horse-power hours (brake horse-power hours) when running at any load between half load and rated capacity. This gives power at less than one-fourth cent per brake horse-power. An efficiency of 38 per cent has been attained. Any good crude or fuel oil can be used as fuel.

CYCLE OF OPERATIONS

As stated above, the fuel is not compressed, only air being in the cylinder during this stage of the cycle, hence pre-ignition is impossible. The clearance is small, being only $\frac{1}{8}$ inch for a 120 horse-power engine. The complete cycle is as follows:

1. Aspiration Stroke. The piston moves to the bottom of the cylinder and during this stroke the air admission valve opens and allows the cylinder to fill with air at atmospheric pressure.

2. Compression Stroke. The piston moves to the upper end of the cylinder. During this stroke the admission valve is closed and the air in the cylinder is compressed to 500 pounds per square inch, at which pressure its temperature is sufficient to ignite any form of petroleum (crude or refined) spontaneously. No valves are open during this stroke and there is nothing in the cylinder but pure air.

3. Expansion Stroke. When the piston has reached the top of the compression stroke and the crank is just crossing the dead center, a small needle valve, Fig. 74, opens and a charge of liquid fuel mixed with compressed air is blown into the incandescent air already in the cylinder. Ignition takes place as the fuel comes in contact with this hot air. The fuel valve, together with the air and exhaust valves, is placed at the side of the cylinder at the top end, and all valves open into the same space. The quantity of fuel is not all blown in at once; instead, fuel injection is maintained for a period equal to 10 per cent of the downward stroke of the piston. It would be impossible to maintain this long period of admission if fuel alone were injected, but the compressed air, which is blown in with the fuel and which is thoroughly mixed with the fuel by the perforated washers that surround the needle valve, increases the

volume and thus gives a quantity whose injection can be controlled. The compressed air referred to is that supplied by the two stage compressor at 800 pounds pressure and cooled before introduction to the fuel valve.

After the needle valve closes, the hot gases expand until the piston has traveled 90 per cent of its stroke, when the exhaust opens to relieve the pressure. The pressure at opening of the exhaust valve for normal load is generally 35 pounds per square inch, and the temperature about 700° F. The pressure in the cylinder is not due to the expansion of gases of combustion alone, for there is a large excess of air present and the high heat attained is sufficient to expand this excess air also.

4. Exhaust Stroke. This fourth and last stroke of the cycle takes place on the upward stroke. The exhaust valve is open and the hot gases are forced out by the piston. When the piston reaches the top center, the exhaust valve closes, the admission valve begins to open and the cycle is repeated.

The engine is water cooled and the valves are operated as shown in Fig. 73. *A* is a cam on the countershaft, *B* is the cross rod with a roller bearing on the cam *A*, and *C* is the push rod that actuates the valve stem. Splash lubrication is used for the cylinder, and the main bearings are lubricated by an oil ring and an oil chamber. The fuel valve is made of nickel steel to prevent abrasion by the petroleum. The piston is of the long trunk type, being approximately $2\frac{1}{2}$ times the diameter in length, tapering $1/32$ inch, and provided with four snap rings.

Governor. The governor is connected to a by-pass at the fuel pump. The pump runs at constant speed. If the load is light and the fuel requirement is low, the governor holds the by-pass valve open and allows a large amount of oil to return to the suction side of the pump; when the load increases, more oil is required; the governor holds the by-pass open for a shorter period, less oil goes back to the pump suction and more goes to the engine.

Valve Group. The group consists of the air and exhaust valves, which require no special consideration, and the fuel valve. This last consists of a needle valve *A* which is cam actuated through the bell crank lever *D*, always opening for the same length of time each

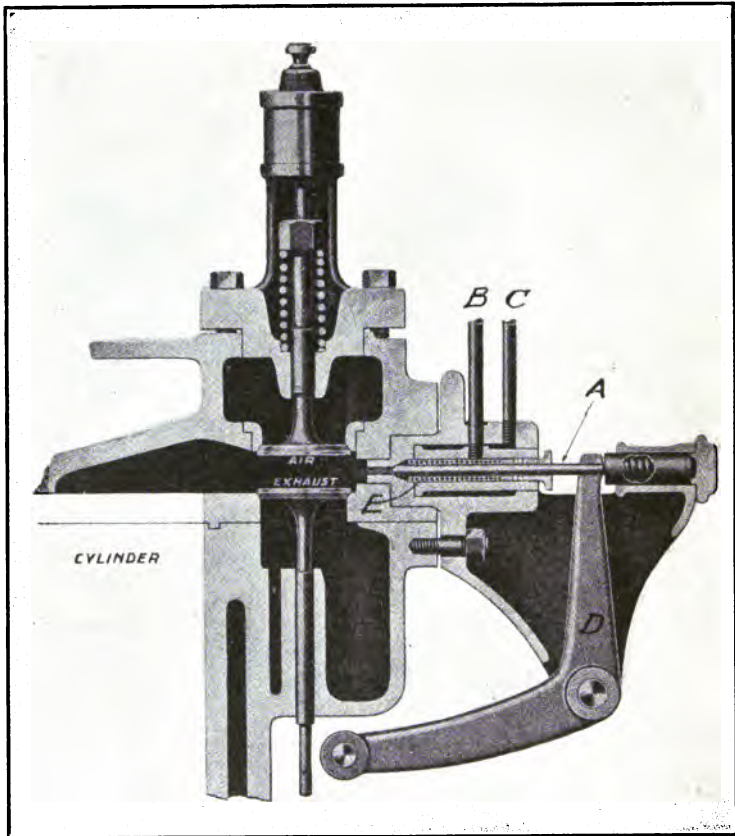

FIG. 74.—Valve Group, Diesel Engine.

cycle. Fuel is introduced through the pipe *B*, the amount being regulated by the governor for each cycle as stated above. Compressed air, which is previously cooled, enters at *C* and the perforated washers *E* serve to mix this air with the fuel. When the needle valve is opened the compressed air blows the fuel into the cylinder.

The 20th Century Motor

20th CENTURY
INTERNAL COMBUSTION ENGINE
BUILT BY
NEW YORK PATENT ENGINEERING CO.
PATENT ENGINEERS 215 N. 5TH ST.
CITY OF NEW YORK, N. Y.
MADE IN U. S. A.
MODEL 200

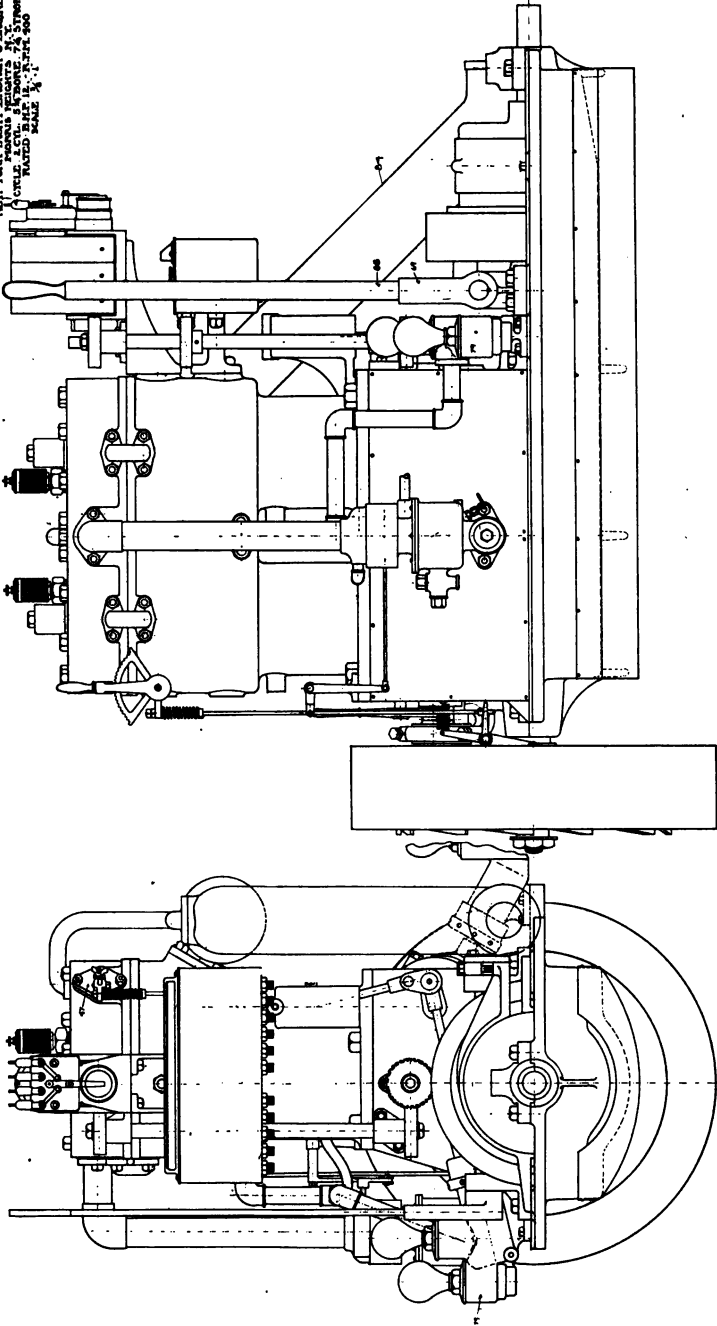

FIG. 75.—20th Century Engine.

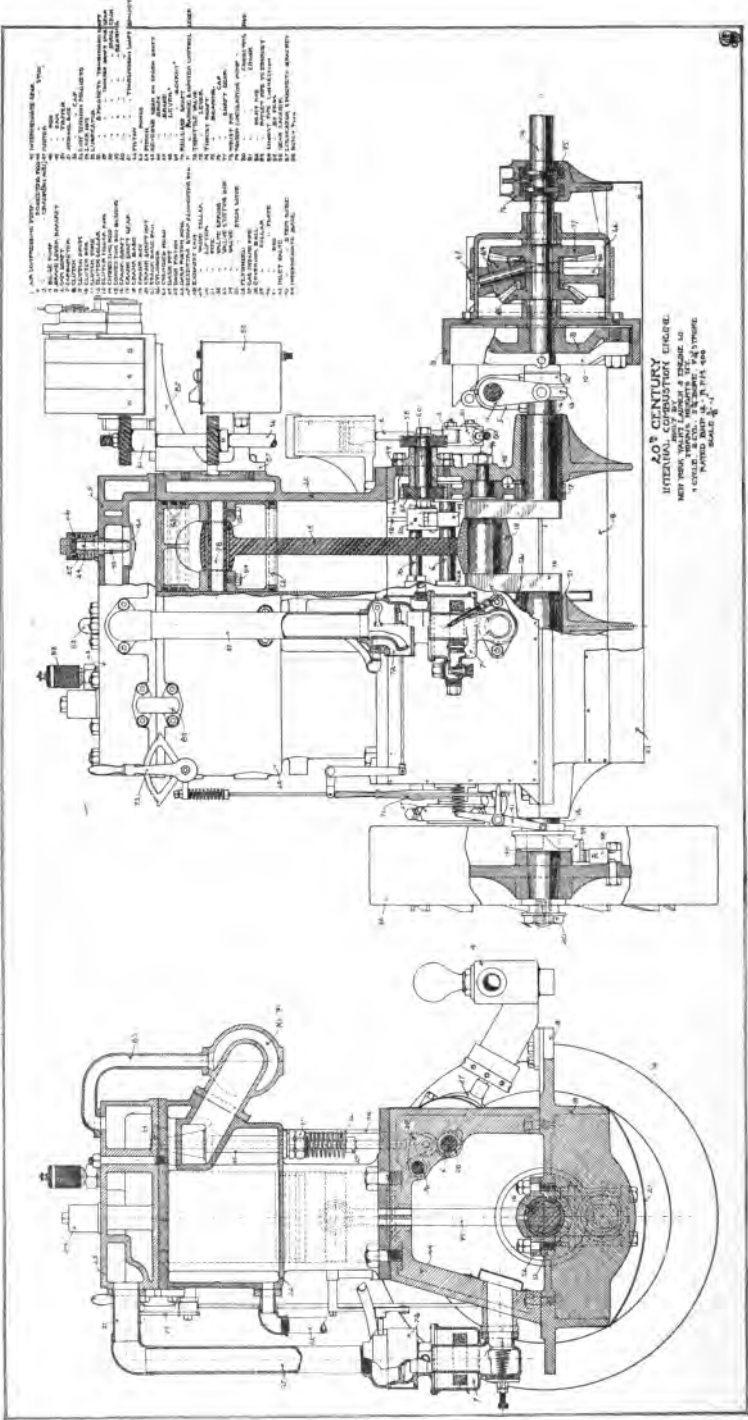

Fig. 76.—20th Century Engine, Cross Section.

Details of 20th Century Engine

The 20th Century gasoline marine engine is of the 4 cycle type. A 12 horse-power engine is installed in one of the launches at the Naval Academy. It is illustrated in Figs. 75 and 76, which are self explanatory. Figs. 77-79 show some of the constructional details.

**FIG. 77.—Carbureter.****FIG. 79.—Piston, Rings, Rod and Bearings.****FIG. 78.—Igniter**

The Jaeger Engine

A view of the Jaeger gasoline marine engine, which is installed in one of the launches at the Naval Academy, is shown in Fig. 80 which requires no explanation.

The Alcohol Engine

The problem of alcohol vaporization was discussed under the chapter on carburetion. The compression is carried higher than in other liquid fuel engines. Recent experiments show that the alcohol engine can be started cold. The Deutz Company spray the alcohol into the admission line near the inlet valve. In appearance the engine is like an ordinary four cycle gasoline engine, but in design, since the useful effect of a given weight of denaturized alcohol is 0.7 that of an equal weight of gasoline, the cylinder dimensions, inlet and exhaust passages, are increased in the ratio of 1.4 to 1 to get equal power. This increase and the modified carbureter are the only points wherein the alcohol engine differs from the gasoline engine. A mixture of equal weights of gasoline and alcohol gives a very efficient performance in the gasoline engine without necessitating change of cylinder design.

Naphtha and Alco-Vapor Engines

These engines, which are really external combustion engines, differ from each other only in the medium used. Naphtha engines use naphtha vapor and alco-vapor engines use alcohol vapor for their mediums. In both cases the medium is heated in an external retort and the vapor tension thus produced is used to drive the piston in a similar manner to the steam engine. The advantage lies in the increased vapor tension of either of these mediums over steam. In construction the engine differs from the internal combustion engine in having small clearance and slide valves. It works on the steam engine cycle. It is built in sizes from 1 to 10 horse-power and is suitable for use in small launches.

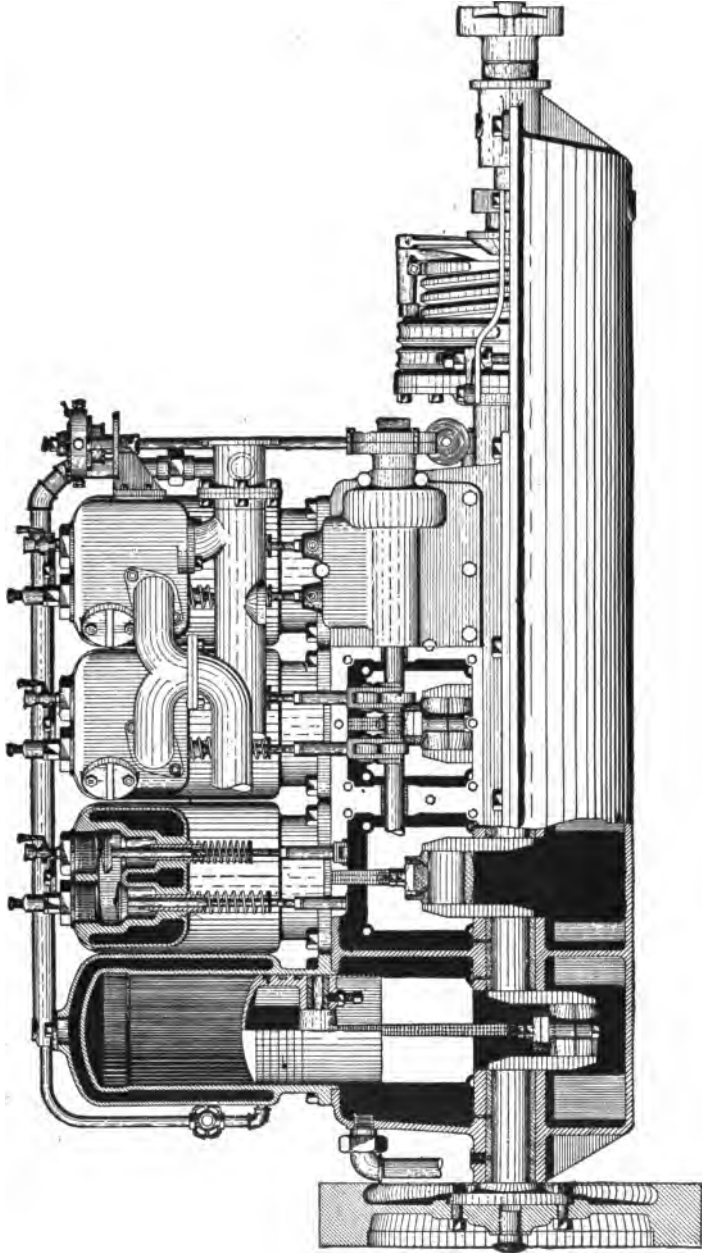

FIG. 80.—Jaeger Engine.

Reversing

Small engines, if reversible, can be reversed by hand, but large reversible engines require an auxiliary, such as compressed air to reverse them. However, but few engines are reversible, so it becomes necessary in marine practice to employ some method of reversing the direction of propeller rotation relative to the engine shaft. The gear installed in the laboratory is shown in Fig. 81. *G* is the engine

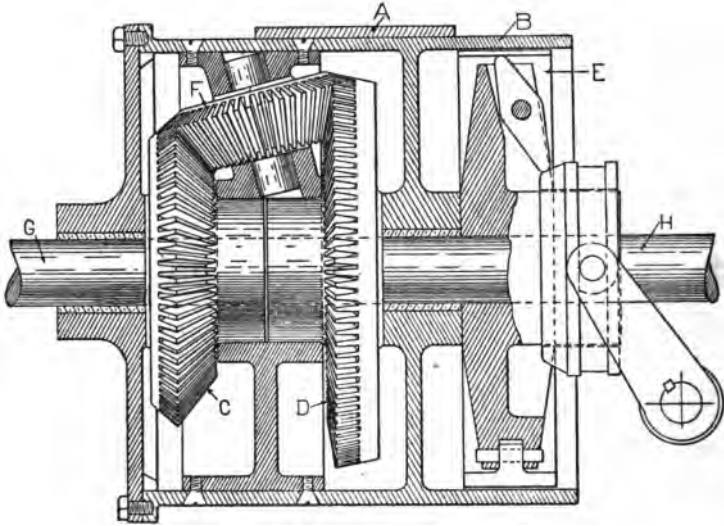

FIG. 81.

crank shaft carrying the bevel wheel *C*. *H* is the propeller shaft which carries the bevel wheel *D*. *F* is a pinion which is carried in bearings cast to the casing *B*, and meshing with the bevel wheels *C* and *D*. *A* and *E* are two friction collars operated by the reversing lever through a clutch in such a manner that either can be locked to the casing *B*, the other being simultaneously unlocked. *A* is made fast to the bed plate or other stationary part of the engine or boat. *E* is firmly fixed to the propeller shaft *H*. The operation is as follows: When going ahead the casing *B* is free to rotate, the friction band *A* being unlocked. At the same time the friction band

E is locked to the casing so that it will revolve with the casing. This locks all the spur wheels, and the casing will now revolve with the engine crank shaft driving the propeller shaft as it is also locked to the casing. To reverse, throw the clutch to the right, releasing the friction band *E*. At the same time the friction band *A* is locked making the casing stationary. Rotation of the engine shaft is communicated through the pinion *F*, which now has a stationary bearing, to the spur wheel on the propeller shaft *H*. The gears reduce the speed on reverse direction. There are three pinions like *F* spaced at equal intervals around the casing.

CHAPTER XI

GAS PRODUCERS

The gas producer furnishes an economical means of generating a suitable gas for use in an internal combustion engine. This field has received considerable attention both in this country and abroad. It is especially applicable to stationary plants, but has been successfully tried in marine practice. At present there is a steamer on Chesapeake Bay operated by a producer plant.

Reactions. Steam and air are blown or drawn through a thick bed of coal. The result is decomposition of the water vapor to H_2 and O , and the combination of this liberated O and the O in the air with the carbon in the fuel to form CO_2 and CO . Fig. 82 gives an idea of the reactions in the generator. As the object is to produce a combustible gas, the aim is to *completely* burn as *little* carbon as possible and to *convert as much as possible* to CO . It is necessary to burn a certain amount to CO_2 in the first zone to furnish to the second zone enough heat to convert the CO_2 into CO .

Fuels Used. Anthracite coal is the most efficient fuel that can be used in a producer plant. This is generally in the form of anthracite peas on account of its cheapness. Non-caking bituminous coal, gas coke, and occasionally charcoal, are also used. The following table shows the approximate composition of the various fuels used in producers:

Fuel.	Carbon.	Volatile Matter.	Ash.
Anthracite	92%	6%	1.5%
Non-caking bituminous.....	70%	20%	8 %
Gas coke	85%	6%	9 %

The last two factors, percentage of volatile matter and ash, have the most influence on the success or non-success of the producer. The volatile products, which are present in large quantities in bituminous coal, distill off in the form of tarry vapors, and these

are extremely difficult to clean out of the gas. This necessitates an elaborate and expensive scrubber for bituminous fuel. The percentage of volatile matter in gas coke does not exceed that in an-

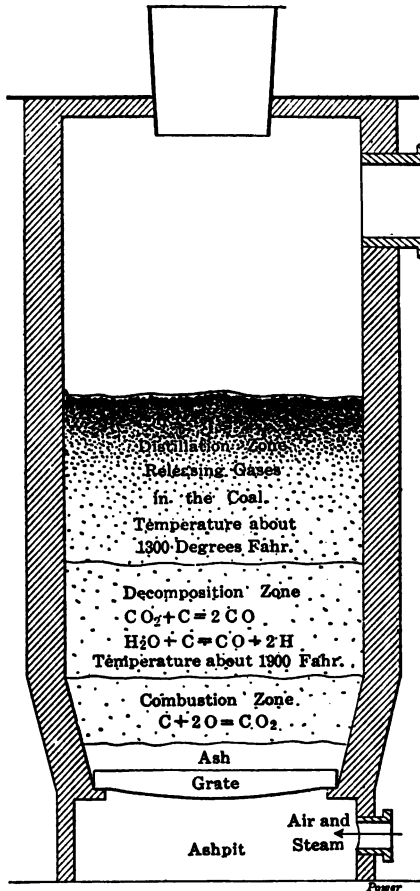

FIG. 82.—Schematic Plan of Producer Showing Zones in Fuel Bed and Reactions that Take Place.

thracite coal, but is of a more tarry nature. The amount of ash present is of importance, for the fusion of this ash forms hard clinkers which may block up the fire and prevent the necessary reactions for producing good gas.

Classification. Gas-producer plants may be divided into three classes according to the method of furnishing air and steam to the fuel:

1. *Suction Producers.* In this type the air and steam are drawn through the fuel by the suction of the engine on the aspiration stroke.

2. *Pressure Producers.* In these air and steam are forced through the fuel by a fan or blower.

3. *Combination Producers.* This system has a fan between the generator and the engine. This fan draws the air and steam through the producer and forces the gas generated to the engine. The generator is therefore of the suction type and the remainder of the plant is of the pressure type.

The Suction Producer

A suction-producer plant consists of four essential parts:

1. The generator.
2. The vaporizer.
3. The scrubber.
4. The purifier, which also acts as an expansion box.

The operation of a suction producer is best illustrated by the earliest practical producer, which was shown by H. Cerdes to the Society of German Mechanical Engineers, Fig. 83. This is used as an example because of its simplicity. Modern improvements are shown later.

Fuel is supplied through the hopper. The engine when running creates a partial vacuum throughout the plant. Air for combustion enters at the air inlet, and in modern practice is preheated. Gas generated leaves at *a* and passes through tubes in the vaporizer *b*. These tubes are surrounded by water which is thus heated, and the steam formed goes to the ashpit through the pipe *c*. Water utilized in the vaporizer is generally the exhaust cooling water from the engine. Its heat is thus retained.

Gas as it emerges from the generator is too hot for use in the engine. It is cooled in the vaporizer, first to reduce its volume, second to prevent back-firing. From the vaporizer the gas goes to

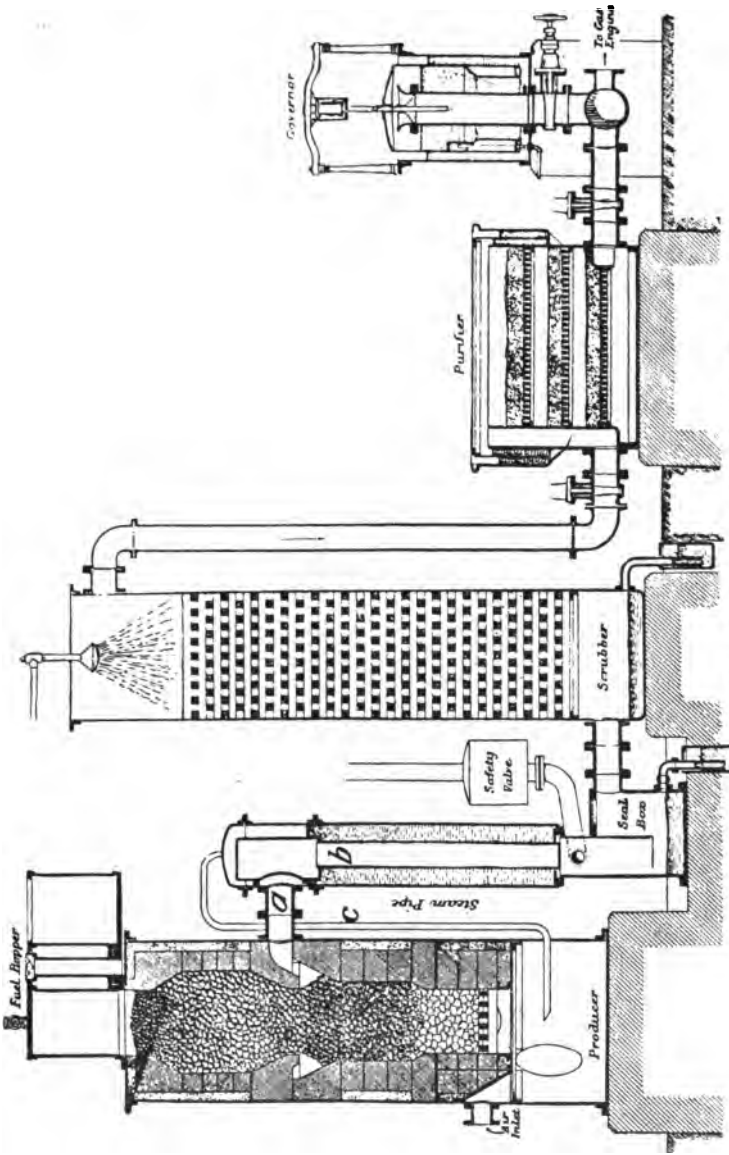

FIG. 83.—The Earliest Practical Producer.

the scrubber through the seal box. The water level shown in the box is that when the engine is running. When the engine is stopped the water overflows from the scrubber to the seal box until the water level rises above the level of the bottom of the partition. This forms a water seal and prevents gas in the scrubber and purifier from backing into the generator when the engine is stopped.

The scrubber is a cylindrical receptacle filled with coke. A water spray keeps this constantly wet. The gas flows in the opposite direction to the water and the latter cleanses the gas of all the entrained tarry vapor and dust, depositing these on the coke. The gas leaves the scrubber by a pipe which leads to the purifier. This is a receptacle containing several layers of sawdust. Here the gas is dried and any small amount of tar or dust which escaped the scrubber is removed. From the purifier the gas passes to the engine.

In modern practice a branch pipe leads from the system between the scrubber and the generator. This branch leads to a chimney and contains a fan. By suitable valves the gas can be diverted from the main line and sent out of the chimney by the fan mentioned. This is used to start the plant. When first started the fan supplies the suction, since the engine is stopped, and the gas given off not being suitable for use in the engine, is allowed to escape to the atmosphere.

Operation. To start the plant, build a fire on the grate, charge the generator through the hopper, open the valve to the chimney and close that to the engine. Start the fan. Gas will now be generated, but at first it is not of a quality to use in the engine. A small pet cock is fitted to the chimney vent for testing the gas. When this is of a suitable quality, shown by its burning at the pet cock with a reddish blue flame, open valve and start engine. After a few revolutions of the engine the plant is self operative and the fan can be stopped and the chimney valve closed.

To stop the plant, stop engine, fill generator with coal, and open chimney valve enough to supply just sufficient air to maintain a fire. The chimney valve and valve to the engine are generally so arranged that closing one opens the other.

The Generator. The generator is in effect a large steel furnace, fire-brick lined, with a grate, ashpit, etc. A hopper is fitted at the top through which the fuel can be supplied without stopping the engine. It is belled at the top as seen in Fig. 84 to create a gas circulation. If the gas were drawn off at the top of the furnace it would contain a large percentage of the volatile gases of the fuel. These are high in tarry vapors and ammonia. By diverting these

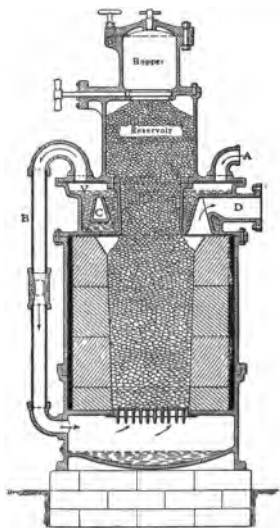

FIG. 84.—Combined Generator and Vaporizer.

gases back through the hot bed of fuel by the belled top, they are partially decomposed and form CO and H_2 . Sometimes a syphon injector is fitted to the top of the generator for this purpose.

Many plants have the vaporizer built into the top of the generator as shown in Fig. 84. A means is also frequently provided for pre-heating the air. This is essentially foreign practice. The hot gases from the fuel bed circulate around the passage C . The water in V is heated by this means and by contact with the fuel chamber partition. Air entering at A picks up the steam formed in V and carries it to the ashpit through B .

Vaporizer or Economizer. When the gases leave the generator their temperature is too high for use in the engine and they must be cooled. To prevent waste of heat taken from them during this cooling process, upon leaving the generator they are passed through the vaporizer or economizer, where some of the heat is given up to the air or is utilized to form the steam used in the generator. As shown in Fig. 84 the vaporizer and economizer is built into the

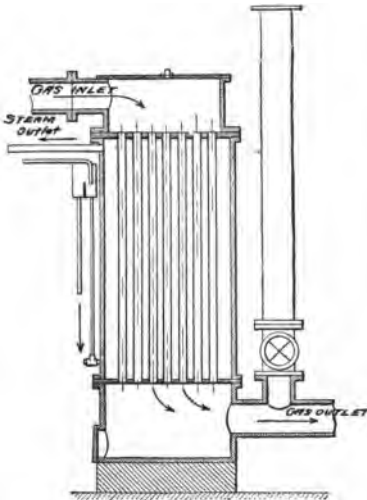

FIG. 85.—Vaporizer.

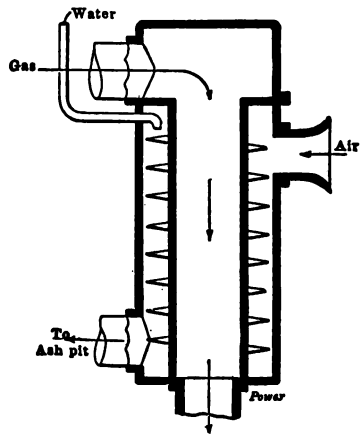

FIG. 86.—Combined Vaporizer and Economizer.

generator. If a separate unit the vaporizer takes the form shown in Fig. 85. Fig. 86 shows a combined vaporizer and economizer, which forms the necessary steam and preheats the air simultaneously. Within the main shell is mounted a concentric flue having spiral ribs around the outside. The hot gases pass down the central flue; water fed to the spiral ribs is vaporized by the heat from the gases, and air passing between the ribs and shell is heated and at the same time picks up the steam formed and carries it to the ashpit.

The Scrubber. After passing through the vaporizer, or upon leaving the generator, if of the form shown in Fig. 84, the gases next go through the scrubber. This serves to cool them further and principally to remove the tarry vapors and minute particles of dust, ash, grit, etc., which they have picked up from the fuel in the generator. The wet scrubber is a cylindrical shell almost

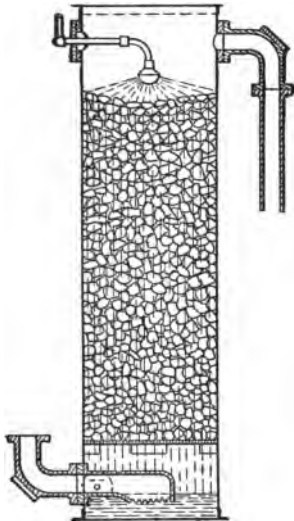

FIG. 87.—Coke Filled Scrubber.

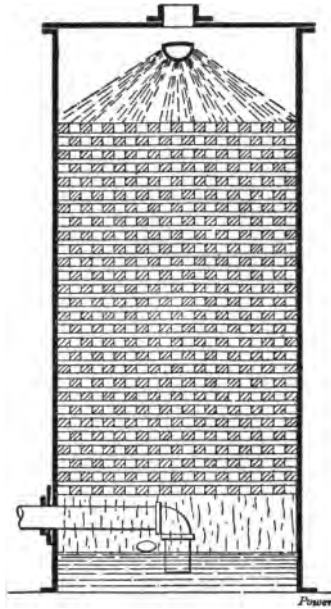

FIG. 88.—Lattice Filled Scrubber.

filled with crushed coke or with wooden grids. It contains a water spray at the top which keeps the coke covered with a cool film of water at all times. As the gases pass up through the filling of the scrubber they come in contact with the wet surface of this "filling" and deposit the impurities thereon. Fig 87 illustrated a coke filled scrubber and Fig. 88 a lattice filled one. The gases entering at the bottom of the scrubber pass through the pool of water formed by the spray. The gas pipe mouth is below the surface of the water and as the gases pass through this water the larger impurities are removed. The gases pass out at the top to go to the dry purifier.

The Purifier. The dry purifier is practically a filter, consisting of a box filled with sawdust, excelsior, or similar material. Here the gas is dried and any impurities that escaped the scrubber are removed. The gases enter from below the excelsior, which is sup-

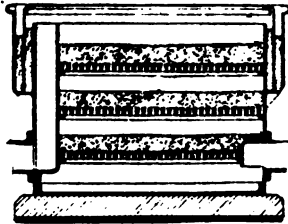

FIG. 89.—Dry Scrubber or Purifier.

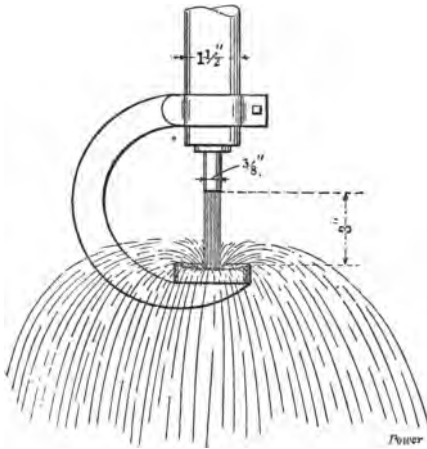

FIG. 91.—Suggested Form of Spray Nozzle.



FIG. 90.—Combined Wet and Dry Scrubber.

ported on shelves, pass through the filler and out the top to the engine. A dry scrubber is shown in Fig. 89. In some cases the purifier and scrubber are combined as shown in Fig. 90. Much trouble has been experienced in getting a spray nozzle that would cover the coke evenly. The form shown in Fig. 91 has been suggested. The holes in an ordinary spray nozzle clog easily and the result is a

deficient water supply. In the type suggested the spray pipe opening is reduced to about $\frac{3}{8}$ inch by a bushing. As the water emerges from this in a solid stream it falls upon a shallow saucer supported from the delivery pipe by a bracket. This should give an efficient spray that cannot become clogged.

Pressure Producers

In the pressure producer air and steam is forced through the fuel bed by a fan or blower, and the ashpit is generally of the closed type. Steam for the generator is generally furnished by a separate boiler, and since the production of gas is not regulated by the demand as in the suction type, a gas holder is usually necessary. No vaporizer is present when a separate boiler is used, but an economizer is usual for preheating the air. As the ashpit is of the closed type, it is necessary to make provision for removal of ashes without stopping the generation of gas.

A schematic plan of a pressure producer is shown in Fig. 92. *A* is a small steam boiler for making steam and producing the necessary air pressure; *B* is the generator; *C* is the economizer with superheater and wash box; *D* is the scrubber and *E* the purifier; *F* is the gas holder, consisting of a steel tank supported by guide framing upon which it travels up and down. The fan or blower is interposed between the generator and economizer in the air line. The drips shown are for the removal of water from the gas.

In operation, the gases generated in the producer enter the superheater and economizer. Here the gas preheats the air to be used in the generator. The gas passes through the economizer and the wash box, depositing a large portion of its extraneous suspended matter. This wash box acts as a seal or non-return for gases stored in the holder and present in other parts of the system. From the wash box the gas enters the scrubber, goes to the purifier and finally enters the holder which stores up a supply sufficient for starting and running for several minutes. The chief function of the holder is to regulate the pressure and variations in consumption and mixture of the gases.

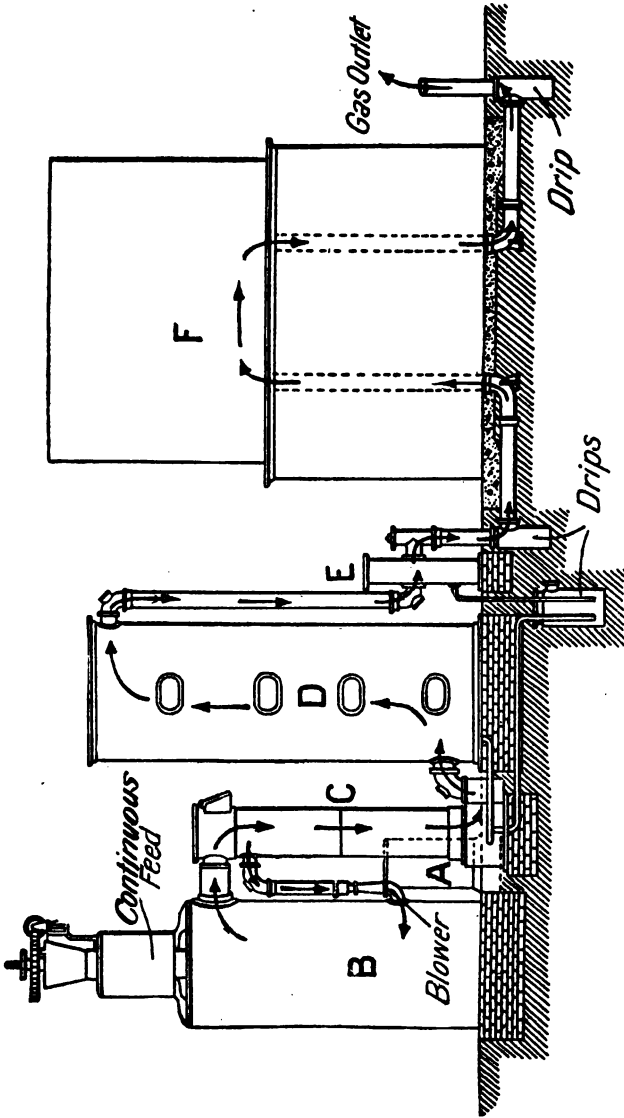

FIG. 92.—Schematic Plan of Pressure Producer.

Combination Producers

The combination producer plant is very similar to the pressure type, the elements being the same. The fan or blower is inserted between the generator and the engine, generally just after the scrubber, thus putting the generator under suction and the remainder of the plant under pressure. Many plants are of the double producer type, two generators being used in parallel. The Loomis-Pettibone is an example of this type, Fig. 93.

Generators. The unit consists of two generators, cylindrical, of iron and steel, lined with fire bricks, with arches at the bottom to support the fuel. Charging and the admission of air is provided for by doors at the top. Two cleaning doors above the arches and one below, opening into the ashpit, are provided. Steam connections are made from the boiler to the ashpit and to a point above the fires in each generator.

Boiler. The boiler is of the multi-tubular type and connected at the base with the generators by means of brick-lined flues. These connections are controlled by the water cooled valves *A* and *B*. All the hot gases pass through the boiler from the generator and give up a large proportion of their sensible heat, thereby producing steam, which, in turn, is used in the fires of the generator.

Wet Scrubber. This is of the coke type, the coke being carried on trays.

The Exhauster. This is a blower in the line between the wet scrubber and the dry scrubber. It maintains sufficient vacuum on the fires to create a down draught through the fires, and sufficient pressure to deliver the gas to the holder.

Valves *C* and *D* control the course of gas delivered by the exhauster. The purge stack valve *C* is only opened when starting the plant, and valve *D* is on the line to the dry scrubber. When one is opened the other is closed.

The Dry Scrubber. The dry scrubber is of the usual type, except that it consists of two chambers so arranged that one can be cleaned while the other is in operation.

The gas holder is of the standard type.

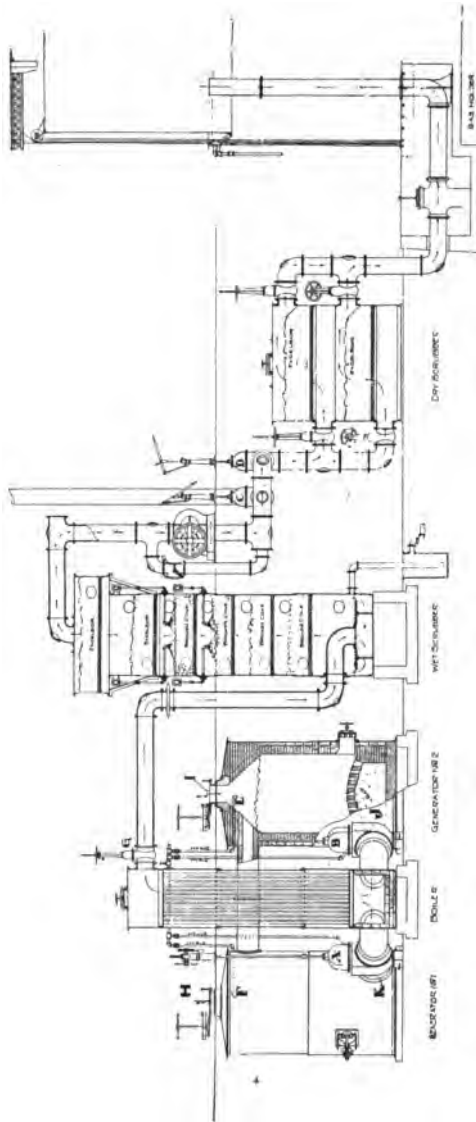

FIG. 93.—Loomis-Pettibone Combination Producer.

Operation. Fires are kindled with coke and wood in the generators to a depth of about four feet, the exhauster creating a downward draught, with top doors *H* and *I*, and valves *A*, *B*, *G* and *C* open, and valve *D* closed. As soon as the fires are thoroughly kindled, steam is admitted into the top of the generators at *F* and *E*, and mingles with the air admitted through top doors *H* and *I*, which the operation of the exhauster draws down through the fresh charge of coal and then through the hot fuel bed beneath. The resultant producer or generator gas is drawn down through the grates and ashpits of generators 1 and 2, valves *A* and *B* being open, passes up through the vertical boiler, and so on through valve *G* to the scrubber and exhauster. Valve *C* is then closed and valve *D* opened, and the gas is driven through the dry scrubber to the gas holder.

Coal is charged through the open top doors as needed.

The making of gas is according to the demand, as the speed of the exhauster is automatically regulated so as to keep the holder full.

The charging doors being open while the air is passing down through them, the operator can see the exact condition of the fires and charge the coal to such parts of the fires as most need it, thereby avoiding the necessity for poking the fires.

The condition of the fires is regulated by occasionally passing steam up through one generator and down through the other for a fraction of a minute. This is accomplished by closing the top doors and valve *B* and introducing steam at *J*. The steam is introduced alternately into generators 1 and 2 by using alternately the valves *A* and *B* and steam inlets *J* and *K*.

When bituminous coal, wood or other fuels containing tar and volatile matters are used in these generators, all the gas and tarry matters distilled from the fresh fuel in the upper strata of the fire pass down through the deep fuel bed, the resultant gas *being fixed and free from tar*.

Experiments have been made on two generators connected in series, this with the object of removing the tarry vapors generated in the first unit by decomposition in the second. No practical plant of this type is now in use.

Advantages of the Various Types

The suction type of producer is simpler and cheaper than the pressure type. It requires no boiler for generating the steam needed (this is not an advantage in all cases as some pressure producers generate their steam by a vaporizer built into the generator), no gas holder is required, and the proportion of steam and air that is admitted to the generator is under control, hence less trouble is experienced with clinkering. The amount of gas produced is regulated by the engine. The washing apparatus is much simpler and cheaper. As the plant is under a slight vacuum a leak will not cause a loss of gas; instead a small amount of air will enter the plant. It requires less attention than the pressure plant.

The two principal advantages of the pressure type are: (1) it can produce gas more cheaply than the suction type, and (2) very poor grades of fuel, even slack and peat, can be used, whereas the suction type as manufactured in this country requires the best quality of coal or coke.

Gas can be produced more cheaply by the pressure than the suction system because, when using the former, valuable by-products are recovered which cannot be saved in the suction producer. The value of ammonia alone which is recovered reduces the cost of production to such an extent that pressure producer gas can be manufactured and sold at a profit for less than five cents per 1000 cubic feet.

INDEX.

	PAGE		PAGE
Acetic acid in cylinder.....	10	Classification of I. C. E.,	
Acetylene, use in engines of.	14	cyclic	34
Admission, best temperature		thermodynamic	39
for	48	Clearance	15, 90
Advanced spark	76	Coil windings, four cylinder	
Advantages of compression..	40	ignition	54
Advantages, relative of steam		one cylinder ignition.....	52
and I. C. E.....	18	Coke oven gas.....	12
relative of two and four		Combustion, rate of.....	15
cycle	37	Compounding the I. C. E... ..	20
After burning	90	Compressed air, starting by,	
Air cooling	66	83, 106	
Alcohol	10	Compression	15, 34, 40
advantages of	11	efficiency depends upon....	82
carburetion of	49	limits of	41
denatured	10	lost	88
engine	122	Connecting rod	27
thermal efficiency of.....	11	Constructional details	23-33
Alco-vapor engines	122	Cooling cylinder by air.....	66
Atomizing vaporizers	49	water	64
Back firing	73, 86	Cooling gases	64
Balancing crank arms.....	29	system	17, 64
Beau de Rocha's principle... ..	21	valves, pistons, etc.....	65
Blast furnace gas.....	13	Countershaft	33
Blowing	88	Cracking process	7
Booster	54	Crank chamber explosions... ..	88
Carbon deposits, knocking due		Crossley vaporizer	49
to	88	Crude oil	10
premature ignition due to..	88	Cut-off	15
Carbureter	42	Cycle defined	34
defects	89	Cycle, Diesel	116
double float type.....	50	four or Otto.....	34
requirements of good.....	44	theoretical	75
Schebler	44	two or clerk	34, 36
Carburetion defined	42	Cylinders	23
of air	42	air cooled	23, 66
of alcohol	49	copper jacketed	24
of gas	43	<i>en bloc</i>	24
of gasoline	43	two cycle	25
of kerosene	48	water cooled	23
of oil	51	Defects in operation, common.	86
spray	44	Deflegmator	6
surface	43	Development of the I. C. E... ..	20
Carburizer	42	Diesel engine	114
Cards, indicator	74	cycle	116
Charge	42	valve group	118
		Dissociation theory	90

	PAGE		PAGE
Distillates, heavy	10	natural	13
Double acting engines 38, 95, 104	104	oil	11
Dual ignition	60	producer	3, 126
		water	2
Economizer	132	Gasoline	8, 43
Effect of heat before compression	83	volatility as test for	9
Efficiency depends upon degree of compression	82	Generator	131, 138
Efficiency, thermal of steam and I. C. E.	82	Gnome engine	106
Engine, acetylene	14	Governing by adjustable spark combination systems	74
alcohol	122	exhaust	74
alco-vapor	122	hit and miss system	69
Diesel oil	114	throttling	72
Gnome aeroplane	106	variable mixture	72
Jaeger launch	122	varying compression	74
Knight slide valve	108	Governor, pick-blade	71
Koerting two cycle gas	95	Governors and governing	69
losses in the	18		
Mietz and Weiss kerosene	113	Hammer break igniter	59
multicylinder	91	Heat balance	18
Standard double acting	104	Heat engine efficiency	82
Sterling	100	Horse-power, brake	78
Twentieth Century launch	119	indicated, how obtained	78
Engler's experiment	4	Hot tube ignition	62
Exhaust, underwater	33		
Exhauster	138	Ignition	16, 35, 52
Explosions, admission pipe	86	by heat of compression	63
carbureter	87	comparison of different systems of	60
crank chamber	88	dual	60
muffler	87	early	76
weak	87	electric	52
		faulty	85
Flame propagation, rate of	15	four cylinder	54
Float valve carbureter	44	hammer break	59
Fly wheel	29	hot tube	62
Fractional distillation	5	jump spark	52
Fuel, classification of	1	late	76
considerations governing selection of	1	make and break	57
gaseous	11	multicylinder	54
heating values of	1-13	premature	41, 88
liquid	4	wipe spark	58
oil	10, 51	Ignition plugs	52, 58, 59
solid	2	Ignition wiring	52, 54
system	16	Indicators for I. C. E.	78
Gas, acetylene	14	Indicator cards	74
air	2	charge throttled	75
blast furnace	13	faulty admission	77
calorific value of	1-3, 11-14	faulty exhaust	77
coke oven	12	ignition advanced	76
illuminating	12	ignition retarded	76
		normal	75
		two cycle	78

	PAGE		PAGE
Internal Combustion Engines—		Naphtha engine	122
for aeroplane use.....	20, 106	Natural gas	13
for battleship use	21	Normal indicator card.....	75
for marine use..	21, 100-106,		
	114-123	Oil, cylinder lubricating.....	67
Jacket, water, temperature...	20	fuel	10, 51
Jump spark coil.....	53	gas	11
Jump spark ignition.....	52	ring	68
Kerosene	9	Operation	83-86
carburetion of	48	Overheating	87
engine	113		
Knight slide valve motor....	108	Petroleum products	8
Knocking, spark, gas, and car-		Petroleum, source, formation,	
bon	88	and composition of.....	4
Koerting double acting gas		refining	5
engine	95	Phases in four cycle engine..	34
La Costa timer	56	Phases in two cycle engine..	36
Late ignition	76	Pick-blade governor	71
Liquid acetylene	14	Pintsch oil gas producer.....	11
Long and short stroke.....	89	Piston	25
Losses in the I. C. E. and		head, two cycle type.....	27
steam engine	19	lubrication	67
Low's method	12	Plug, spark	53
Lubricating oil, requirements		Premature ignition	41, 88
of good	67	Pressure diagram	91
Lubrication	66	Pressure gas producers.....	136
Lubricators	67	Producers, gas	126
Lunkenheimer mixing valve..	47	advantages of various types.	141
		classification of	128
Magneto, high tension.....	54	combination	138
low tension	54	for marine use	126
with automatic spark ad-		fuels used in	126
vance	107	Loomis-Pettibone,	138
Make and break ignition....	57	Loomis-Pettibone, operation	
Management	83	of	140
Manograph	78	pressure	136
Master vibrator	61	pressure, operation of.....	136
Mechanical ebullition	43	reactions in	126
Medium	42	suction	128
Mietz and Weiss kerosene en-		suction, operation of.....	130
gine	113	Pump, gas	37, 98
Misfiring, continuous	86	oil	114
intermittent	87	water	64
Mixing valve	42, 44	Purification of petroleum dis-	
Lunkenheimer	47	tillates	6
Mixture, lean and rich	15, 42	Purifier	134
Muffler	29	Push rod	28
ejector	31		
explosion	87	Ratio of expansion	15
gas pipe	31	Reduction gear for counter-	
Thompson	30	shaft	32
Multicylinder ignition	54	Residuum	6
Multicylinder timer	55	Reversing	124
		Rings, piston	25

	PAGE		PAGE
Scavenging the cylinder.....	91	Temperatures at which frac-	
Scrubber, combined, wet and		tions distill	7
dry	134	Three point suspension	103
wet, coke and lattice.....	133	Thermo-syphon system	65
Secondary spark gap.....	92	Timer, La Costa	56
Shaft, crank	103	Splitdorf	55
Smoky exhaust	88	Trouble hunting	85
Spark coils	53, 54	Types of I. C. E.....	38
Spark plug	53	Vacuum process	7
Splash system of lubrication..	67	Valve gears	28, 32
Splitdorf timer	55	Valves	27
Spray carburetion	44	requirements of efficient...	28
Spray nozzle for scrubber....	134	rotary	28
Standard double acting gaso-		slide	28
line engine	104	Vaporizer, fuel	49
Start, failure to.....	84	gas producer	132
Starting an I. C. E.....	83	Water cooled engine.....	64
Starting on spark.....	84	Water cooled valves, pistons,	
Still, horizontal American....	5	etc.	65
Stopping an I. C. E.....	83	Water gas	2
Straining gasoline	89	Water jacket	24
Stratification theory	90	Weak explosions	87
Submerged exhaust	33	Wipe spark igniter.....	58
Suction producer	128	Wrist pin	27
Surface carburetion	43		

part
p. te us so

